Electric Vehicle Supply Equipment (EVSE)

- Metrological and technical requirements
- Metrological controls and performance tests

Systèmes d'alimentation pour véhicules électriques (SAVE)

- Exigences métrologiques et techniques
 - Contrôles métrologiques et essais de performance
-



Contents

Explanatory note.....	3
Foreword	4
Part 1 Metrological and technical requirements	5
1 Scope.....	5
2 Terms and definitions.....	5
2.1 General terms.....	5
2.2 Definitions	7
2.3 Metrological characteristics	9
3 Metrological requirements	13
3.1 Units of measurement	13
3.2 Rated operating conditions	13
3.3 Accuracy requirements	14
3.4 Durability	19
4 Functional requirements.....	19
4.1 Markings	19
4.2 Suitability for use.....	20
4.3 Access to data	23
4.4 Protection of metrological properties.....	25
Part 2 Metrological controls and performance tests	32
5 Type approval	32
5.1 Documentation.....	32
5.2 Type definition.....	33
5.3 Software validation procedure	34
6 Test programme	34
7 Test procedures for type approval.....	35
7.1 Test conditions	35
7.2 Tests for compliance with maximum permissible errors	36
7.3 Tests for influence quantities	37
7.4 Tests for disturbances	45
8 Examination for conformity with type.....	57
9 Verification and re-verification.....	57
9.1 General.....	57
9.2 Testing	57
9.3 Reference conditions for initial and subsequent verifications in a laboratory	58
9.4 Additional requirements for statistical verifications	59
9.5 Field testing.....	60
Annex A.....	61
Annex B.....	67
Annex C.....	68

Explanatory note

As a result of the transition from fossil fuels to sustainable forms of energy, worldwide developments in the area of charging electrical vehicles (EVs) are proceeding at a rapid pace. In this newly developing market, it is important that trading parties have confidence that the amount of energy transferred is measured fairly and accurately. Regulators in various individual economies have started, or are starting, initiatives to develop national or regional metrology regulations for Electrical Vehicle Supply Equipment (EVSE), for which the requirements are not always mutually exchangeable.

The need for international guidance on metrology for EVSE was already agreed upon by the CIML at its 51st meeting in 2016 in Strasbourg, where the Committee decided on the mandate to revise OIML R 46:2012 *Active energy electricity meters*. Recommendations for EVSE metrology were initially foreseen to be included in the next version of R 46. By 2021, however, it became apparent that the needs of the EVSE market and of regulators were more urgent than could be met by the timeline expected for the publication of the revised R 46. Initial work on international harmonisation of EVSE requirements and test procedures was carried out as part of the revision process for R 46. This effort was subsequently split off into a separate Project Group, established following CIML approval of the relevant project proposal in October 2021. The existence of the new Project Group allowed the development of a self-contained OIML publication for EVSE, separate from R 46, and which could be published on a faster timeline than that of the ongoing revision of R 46. While there are obvious similarities between ‘traditional’ (utility type) electricity metering and charging EVs, there are also profound differences. This separate OIML publication for EVSE allows for a clear treatment of the unique aspects of EV charging, such as the direct sales nature of transactions, means of conveying the measurement result, and typical progressions of current levels over time.

Initially this new Project Group determined that the most expedient way to introduce guidance related to EVSE would be to develop a Guide based on many aspects of OIML R 46. This resulting OIML Guide, G 22 *Electric vehicle supply equipment*, while based on OIML R 46, is not a generally applicable metering document, but rather a purpose-specific application with different use and application. The intention of this Guide is to provide a blueprint for requirements and procedures for type testing, to be used by national regulators and approval authorities to set up their own legislation. In this Guide, the EVSE is considered as a unique, built-for-purpose system, which incorporates AC or DC energy metrology. Whether the metrology in the EVSE is accomplished using a separately type approved meter, or integrated into the electronics of the EVSE, does not affect the requirements for testing, or the performance of the EVSE.

Practical technical experience in testing and approving DC charging is lacking in some respects. However, DC charging applications constitute an important, growing portion of the EV charging market, and fair trade of electrical energy in DC is deemed at least as important as in AC. Measuring DC energy by EVSE is therefore explicitly covered in this Guide, albeit in a rudimentary way.

Immediately following the development of this Guide, the same OIML Project Group will continue working to produce a full Recommendation on EVSE. The major parts of this Guide are already styled as “Part 1” and “Part 2” of an OIML Recommendation. The Recommendation will be a fine-tuned, more elaborate version of the text of this Guide, and will contain all the mandatory parts. Once the Recommendation on EVSE is published, the OIML intends to retract this Guide.

Foreword

The International Organisation of Legal Metrology (OIML) is a worldwide, intergovernmental organisation whose primary aim is to harmonise the regulations and metrological controls applied by the national metrological services, or related organisations, of its Member States.

The main categories of OIML publications are:

- **International Recommendations (OIML R)**, which are model regulations that establish the metrological characteristics required of certain measuring instruments and which specify methods and equipment for checking their conformity. OIML Member States shall implement these Recommendations to the greatest possible extent;
- **International Documents (OIML D)**, which are informative in nature and which are intended to harmonise and improve work in the field of legal metrology;
- **International Guides (OIML G)**, which are also informative in nature and which are intended to give guidelines for the application of certain requirements to legal metrology; and
- **International Basic Publications (OIML B)**, which define the operating rules of the various OIML structures and systems.

OIML Draft Recommendations, Documents and Guides are developed by Project Groups linked to Technical Committees or Subcommittees which comprise representatives from OIML Member States. Certain international and regional institutions also participate on a consultation basis. Cooperative agreements have been established between the OIML and certain institutions, such as ISO and the IEC, with the objective of avoiding contradictory requirements. Consequently, manufacturers and users of measuring instruments, test laboratories, etc. may simultaneously apply OIML publications and those of other institutions.

International Recommendations, Documents, Guides and Basic Publications are published in English (E) and translated into French (F) and are subject to periodic revision.

Additionally, the OIML participates in Joint Committees with other Institutions for the development of **Vocabularies (OIML V)** and **Joint Guides** and periodically commissions legal metrology experts to write **Expert Reports (OIML E)**. Expert Reports are intended to provide information and advice, and are written solely from the viewpoint of their author, without the involvement of a Technical Committee or Subcommittee, nor that of the CIML. Thus, they do not necessarily represent the views of the OIML.

This publication – reference OIML G 22:2022 (E) – was developed by OIML Project Group TC 12/p 3 *Electric Vehicle Charging Stations*. It was approved for final publication by the President of the International Committee of Legal Metrology in September 2022. The same Project Group will continue to develop this Guide into a full OIML International Recommendation.

OIML Publications may be downloaded from the OIML website in the form of PDF files. Additional information on OIML Publications may be obtained from the Organisation's headquarters:

Bureau International de Métrologie Légale
11, rue Turgot – 75009 Paris – France
Telephone: +33 1 48 78 12 82
Fax: +33 1 42 82 17 27
E-mail: biml@oiml.org
Internet: www.oiml.org

Part 1

Metrological and technical requirements

1 Scope

This Guide provides guidance on the metrological and technical requirements applicable to Electric Vehicle Supply Equipment (EVSE, both AC and DC) subject to legal metrological controls. The requirements are provided for type approval, verification, re-verification and *in situ* testing. They also apply to modifications that may be made to existing approved devices. This Guide does not apply to wireless charging systems.

The provisions set out here apply only to active electrical energy measurements and computation of transaction billing.

This Guide is structured very similarly to an OIML Recommendation since it is the intention of the Project Group to transform it into a Recommendation as soon as possible.

This Guide does not apply to contractual private transactions as defined in 2.2.16.3.

2 Terms and definitions

The terminology used in this Guide conforms to OIML International Document D 11 *General requirements for electronic measuring instruments* [1], OIML V 2-200:2012 *International Vocabulary of Metrology - Basic and General Concepts and Associated Terms (VIM)* [3] and OIML V 1:2013 *International vocabulary of terms in legal metrology (VIML)* [4]. Terminology from OIML International Document D 31:2019 *General requirements for software-controlled measuring instruments* [2] is also applicable, particularly for 4.4 and the associated validation procedures in 5.3. In addition, for the purposes of this Guide, the definitions in 2.1 to 2.3 below shall apply.

2.1 General terms

2.1.1 Electric Vehicle Supply Equipment (EVSE)

device intended to supply or receive electrical energy to or from an electric vehicle and to measure that energy, store and report the measurement result to the customer, and if necessary, transmit the information to a billing system

2.1.2 EVSE with separately type approved meter

device such as defined in 2.1.1, but for which the basic metrology is provided by a separately type approved meter which has been tested for compliance with a recognised metering standard with equal or more stringent requirements

Note: For EVSE with embedded metrology, the metrology is an integral part of the EVSE. In this case, separate type approval of the embedded metering functionality is not required, since it will be tested as part of the EVSE type approval process.

2.1.3 unitary EVSE

EVSE, with either AC or DC output, in which all of the power and control electronics is located in a single enclosure supplied by the AC mains

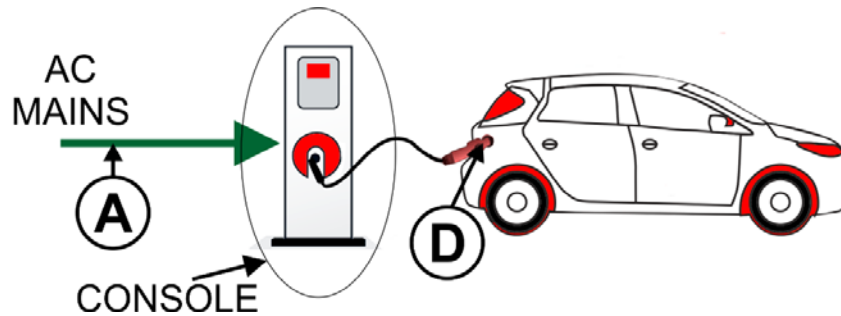

Figure 1 – Unitary EVSE

- A AC mains supply to the EVSE
- D Effective metering point is point of connection to the vehicle

2.1.4 complex DC EVSE

EVSE with DC output which is composed of multiple enclosures connected by DC power busses

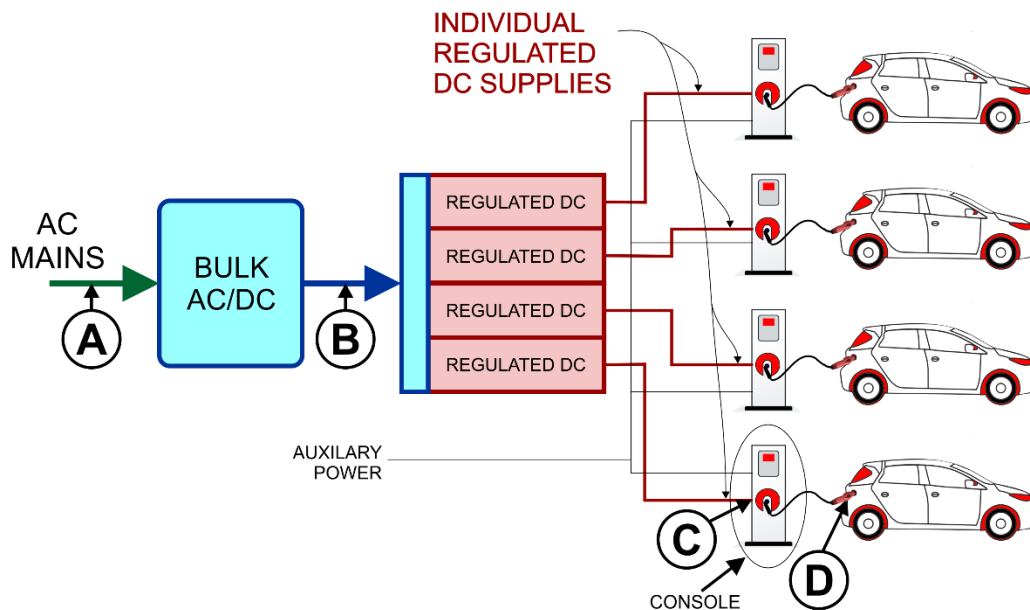

Figure 2 – Complex DC EVSE

- A AC mains supply to the EVSE
- B DC mains supply feed (generally at a fixed voltage, may be unregulated)
- C Regulated DC feed to a specific charging port
- D Effective metering point is point of connection to the vehicle

2.2 Definitions

2.2.1 connection point

point at which one electric vehicle is connected to the fixed installation [definition 3.1.5 of IEC 61851-1]

Note: If the output cable is a fixed part of the charging system, this point is defined as the connector at the end of the cable. Otherwise, the connection point is defined as the point of the charging system at which the cable is plugged in.

2.2.2 client interface

facility of the EVSE that may be local or remote and which provides access to legally relevant transaction data to a user

2.2.3 measuring element

part of the EVSE that transforms a current and a voltage into a signal proportional to the power and/or energy. This may include both analogue and digital sensors and signal processing components

2.2.4 current circuit

connections of the EVSE and part of the measuring element through which flows the current of the electric vehicle to which the EVSE is connected

2.2.5 voltage circuit

connections, components, wiring and cables of the EVSE which provide voltage to the electric vehicle. This includes the power source in DC EVSE (see Figure 2, from the regulated DC output up to and including the connection point)

2.2.6 auxiliary power supply

any power source other than the AC mains connection which provides power to any legally relevant functionality of the EVSE

2.2.7 indicating device or display

part of the EVSE that implements the client interface either continuously or on demand

Note 1: An indicating device may also be used to display other relevant information.

Note 2: An indicating device is local to the EVSE.

2.2.8 register, energy accumulation received

part of the system that stores the total energy received from EV over all transactions

Note: This energy register is the same as the energy received accumulation register in a R 46 compliant meter.

2.2.9 register, energy accumulation delivered

part of the system that stores the total energy delivered to EV over all transactions

Note: This energy register is the same as the energy delivered accumulation register in a R 46 compliant meter.

2.2.10 register, transaction energy received

part of the system that stores the total energy received from EV in a single transaction

Note: This energy register is not the same as the energy accumulation register in a R 46 compliant meter.

2.2.11 register, transaction energy delivered

part of the system that stores the total energy delivered to EV in a single transaction

Note 1: In this Guide unless otherwise noted, register shall mean the transaction energy delivered register.

Note 2: This energy register is not the same as the energy accumulation register in a R 46 compliant meter.

2.2.12 adjustment device

device or function incorporated in the EVSE that allows the error curve to be shifted with a view to bringing errors (of indication) within the maximum permissible errors

2.2.13 ancillary device

device within the EVSE that is not required to be active during the transaction

Note: Since the testing used in this Guide is all transactional, any device which is routinely required to be active during a transaction will have its effect tested automatically. Ancillary devices are devices which may or may not be active at any time but which are not used as part of the transactional process.

Example: An EVSE might have a display which shows advertisements for a business. This would be an ancillary device.

2.2.14 sub-assembly

part of a device having a recognisable function of its own

2.2.15 transaction

process of authorising, connecting to the electric vehicle, delivering/receiving energy, terminating the delivery/reception, presenting the information relevant to the process to the customer, transmitting and receiving acknowledgement of receipt of any relevant information

2.2.16 transaction types

Three types of transaction are recognised. A single EVSE may participate in more than one type of transaction:

2.2.16.1 ad hoc public transaction

transaction for which a recharging service is available to an end user without the need for that end user to register, conclude a written agreement, or enter into a longer-lasting commercial relationship with the operator of that recharging point or with a charging network service provider, beyond the mere purchase of the service

2.2.16.2 contractual public transaction

transaction for which a recharging service is only available to an end user who has concluded in advance a written agreement, or entered into a longer-lasting commercial relationship with the operator of that recharging point or with a charging network service provider

2.2.16.3 contractual private (single user) transactions

transaction for which the use of the EVSE is limited to a single user who has concluded in advance a written agreement, or entered into a longer-lasting commercial relationship with the operator of that recharging point or with a charging network service provider. In this type of transaction, charges may be made based on the total energy consumed over an extended billing period

2.3 Metrological characteristics

2.3.1 current, I

value of the electrical current flowing to or from the EVSE through the connection point. For AC EVSE, the value is the RMS value of the current. For DC EVSE, the value is the average value of the current

2.3.2 starting current, I_{st}

lowest value of current specified at which the EVSE must register electrical energy at unity power factor and, for poly-phase EVSE, with balanced load

2.3.3 minimum current, I_{min}

lowest value of current at which the EVSE is specified to meet the accuracy requirements of this Guide

2.3.4 transitional current, I_{tr}

value of current at and above which the EVSE is specified to lie within the smallest maximum permissible error corresponding to the accuracy class of the EVSE

2.3.5 maximum current, I_{max}

highest value of current at which the EVSE is specified by the manufacturer to meet the accuracy requirements of this Guide

2.3.6 voltage, U

For AC EVSE: RMS value of the electrical voltage supplied to the electric vehicle at the connection point

For DC EVSE: value of voltage supplied to the electric vehicle at the connection point

2.3.7 nominal voltage, U_{nom}

voltage specified by the manufacturer for normal operation of an AC EVSE. An EVSE may have multiple U_{nom}

Note: A DC EVSE has no single nominal voltage, but rather a range of voltages from U_{min} to U_{max} .

2.3.8 nominal output frequency, f_{nom}

frequency of the voltage (and current) specified by the manufacturer for the outpower of the EVSE

Note 1: For AC EVSE, the frequency of the power supplied to the EVSE and the power the EVSE supplies to the vehicle are the same.

Note 2: For DC EVSE, f_{nom} is 0 Hz.

2.3.9 harmonic

part of a signal that has a frequency that is an integer multiple of the fundamental frequency of the power input to the EVSE. The fundamental frequency is generally the nominal frequency, f_{nom} , for AC EVSE

2.3.10 harmonic number

integer number used to identify a harmonic. It is the ratio of the frequency of a harmonic to the fundamental frequency of the signal

2.3.11 distortion factor, d

ratio of the RMS value of the harmonic content (obtained e.g. by subtracting its fundamental term from a non-sinusoidal alternating quantity) to the RMS value of the fundamental term. The distortion factor is usually expressed as a percentage. It is equal to the total harmonic distortion using the fundamental as the reference (denominator)

2.3.12 power factor, PF

cosine, $\cos \varphi$, of the phase difference, φ , between voltage, U , and current, I , under sinusoidal and either single-phase or symmetrical three-phase conditions

Note: An EVSE is only required to measure active energy. Performance is verified using a reference that can measure apparent energy and power factor.

2.3.13 power, instantaneous

rate at which energy is transported. Instantaneous power is the product of voltage and current at each instance of time

$$p(t) = u(t) \cdot i(t)$$

where:

$u(t)$ is the instantaneous voltage

$i(t)$ is the instantaneous current

$p(t)$ is the instantaneous power

t is time

2.3.14 DC ripple

peak-to-peak deviation from the nominal DC signal expressed as a percentage of the nominal DC value

2.3.15 energy, active, E_a

instantaneous active power integrated over time

$$E_a = \int_0^T p(t) \cdot dt$$

where:

E_a is the active energy

T is the total duration of the power delivery in a transaction

t is time

Other symbols are as defined in 2.3.13.

Note: Active energy is usually expressed in kWh or MWh. Refer to 3.1 for requirements on units of measurement.

2.3.16 relative error (of indication)

measured quantity value minus reference quantity value, divided by the reference quantity value. The relative error is usually expressed as a percentage

Note: Since this Guide deals only with relative error, the short form “error” is used for relative error.

2.3.17 maximum permissible error (MPE)

extreme value of measurement error, with respect to a known reference quantity value, permitted by specifications or regulations for a given measurement, measuring instrument, or measuring system [OIML D 31:2019, 3.1.28]

Note 1: Usually, the term “maximum permissible errors” or “limits of error” is used where there are two extreme values.

Note 2: The term “tolerance” shall not be used to designate “maximum permissible error”.

2.3.18 base maximum permissible error (BMPE)

extreme values of the error (of indication) of an EVSE, permitted by this Guide, when the current is varied (AC and DC EVSE) and voltage (DC EVSE) within the intervals given by the rated operating conditions, and when the EVSE is otherwise operated at reference conditions

2.3.19 maximum permissible error shift

extreme values of the change in error (of indication) of an EVSE, permitted by this Guide, when a single influence factor is taken from its value at reference conditions and varied within the rated operating conditions. For each influence factor there is one corresponding maximum permissible error shift

2.3.20 intrinsic error

error of a measuring instrument, determined under reference conditions [OIML D 11:2013, 3.8]

2.3.21 initial intrinsic error

intrinsic error of a measuring instrument as determined prior to performance tests and durability evaluations [OIML D 11:2013, 3.9]

2.3.22 minimum measured quantity, MMQ

minimum quantity of energy delivered in a transaction for which the manufacturer specifies that the EVSE will meet the BMPE of the EVSE’s accuracy class

2.3.23 influence quantity

quantity that, in a direct measurement, does not affect the quantity that is actually measured, but affects the relation between the indication and the measurement result [OIML D 11:2013, 3.15]

Note: The definition of influence quantity is understood to include values associated with measurement standards, reference materials and reference data upon which the result of a measurement may depend, as well as phenomena such as short-term measuring instrument fluctuations and quantities such as ambient temperature, barometric pressure and humidity.

2.3.24 influence factor

influence quantity having a value within the rated operating conditions of the measuring instrument specified in this Guide [OIML D 11:2013, 3.15.1]

2.3.25 disturbance

influence quantity having a value within the limits specified in this Guide, but outside the specified rated operating conditions of the measuring instrument [OIML D 11:2013, 3.15.2]

Note: An influence quantity is a disturbance if the rated operating conditions for that influence quantity are not specified.

2.3.26 rated operating condition

operating condition that must be fulfilled during measurement in order that a measuring instrument or measuring system perform as designed [OIML D 11:2013, 3.16]

Note: Rated operating conditions generally specify intervals of values for a quantity being measured and for any influence quantity.

2.3.27 reference condition

operating condition prescribed for evaluating the performance of a measuring instrument or measuring system or for comparison of measurement results [OIML D 11:2013, 3.17]

Note 1: Reference operating conditions specify intervals of values of the measurand and of the influence quantities.

Note 2: In IEC 60050-300, item 311-06-02, the term “reference condition” refers to an operating condition under which the specified instrumental measurement uncertainty is the smallest possible.

2.3.28 accuracy class

class of EVSE that meets the stated metrological requirements intended to keep measurement errors or instrumental uncertainties within specified limits under specified operating conditions

Note: In this Guide, the stated metrological requirements for accuracy class include permissible responses to disturbances.

2.3.29 durability

ability of a measuring instrument to maintain its performance characteristics over a period of use [OIML D 11:2013, 3.18]

2.3.30 critical fault

failure of the device when subjected to a disturbance in which the device appears to function correctly, but where the legally relevant data is incorrect or the shift in the accuracy measurements exceeds that specified in the tests. Ceasing to function is not a critical fault. If a disturbance interrupts a transaction, then either: (a) the transaction must be cancelled or (b) when the disturbance is removed, the transaction must be completed correctly

2.3.31 checking facility

facility that is incorporated in the EVSE and which enables faults that would otherwise be critical faults to be detected and acted upon in such a way that incorrect registration is prohibited [modified from OIML D 11:2013, 3.19]

Note: Faults that are detected and acted upon by means of a checking facility shall not be considered as critical faults.

2.3.32 bidirectional (energy) flow

capability of an EVSE to measure energy flow in both directions (to the EV and from the EV)

2.3.33 positive direction only (energy) flow

capability of an EVSE to measure energy flow in only one direction (from the EVSE to the EV)

2.3.34 positive (energy) flow

direction of energy flow from the EVSE to the EV

2.3.35 negative (energy) flow

direction of energy flow from the EV through the EVSE to the nominal supply

2.3.36 legally relevant

software/hardware/data or part of the software/hardware/data of an EVSE which influences properties regulated by legal metrology, e.g. the accuracy of the measurement or the provision of transactional information to the customer

2.3.37 legally relevant transaction data

auditable data necessary to finalise a transaction

3 Metrological requirements

3.1 Units of measurement

The active electrical energy shall be expressed using one of the following symbols: Wh, kWh, MWh, GWh.

3.2 Rated operating conditions

Rated operating conditions are specified in Table 1.

Table 1 Rated operating conditions

Condition or influence quantity	Values, ranges				
Frequency ⁽¹⁾	$f_{\text{nom}} \pm 2\%$ where f_{nom} is to be specified by the manufacturer. If the manufacturer specifies more than one nominal frequency, the rated operating conditions shall be the combination of all frequency intervals.				
Voltage	<i>For AC EVSE:</i> For each U_{nom} , $0.9 \times U_{\text{nom}}$ to $1.1 \times U_{\text{nom}}$ <i>For DC EVSE:</i> From lowest output voltage to highest output voltage				
Current	I_{st} is to be specified by the manufacturer. I_{min} is to be specified by the manufacturer. I_{min} shall be less than or equal to I_{tr} . I_{max} is to be specified by the manufacturer.				
	Mode	AC	AC	DC	DC
	I_{tr}	$\leq 5.0 \text{ A}$	$\leq 0.10 I_{\text{max}}$	$\leq 25 \text{ A}$	$\leq 0.10 I_{\text{max}}$
	I_{max}	$\leq 80 \text{ A}$	$> 80 \text{ A}$	$\leq 500 \text{ A}$	$> 500 \text{ A}$
Power factor ⁽¹⁾	≥ 0.9				
Temperature	From lower temperature limit to upper temperature limit as specified by manufacturer. The manufacturer shall specify the lower temperature limit from the values: -55 °C , -40 °C , -25 °C , -10 °C , $+5\text{ °C}$ The manufacturer shall specify the upper temperature limit from the values: $+30\text{ °C}$, $+40\text{ °C}$, $+55\text{ °C}$, $+70\text{ °C}$, $+85\text{ °C}$.				
Humidity and water	With respect to humidity, the manufacturer shall specify the environment class for which the EVSE is intended: H1: enclosed locations where the EVSE are not subjected to condensed water, precipitation, or ice formations; H2: enclosed locations where the EVSE may be subjected to condensed water, to water from sources other than rain and to ice formations; H3: open locations with average climatic conditions.				
Harmonics ⁽¹⁾	<i>For AC EVSE:</i> The EVSE shall operate correctly when the supply voltage distortion is less than 10 % and the load current distortion is less than 3 % at all harmonics indices.				

Condition or influence quantity	Values, ranges
Ripple ⁽²⁾	<i>For DC EVSE:</i> The ripple produced on the output of the EVSE shall comply with IEC 61851-23. The EVSE shall only measure energy having frequencies up to 2 kHz.
Load balance ⁽¹⁾	For polyphase EVSE, the EVSE shall operate correctly with any combination of phases enabled.
MMQ ⁽³⁾	<i>For AC EVSE:</i> the MMQ shall not be greater than 0.1 kWh. <i>For DC EVSE:</i> the MMQ shall not be greater than 1.0 kWh.
⁽¹⁾ Only applies to AC EVSE.	
⁽²⁾ Only applies to DC EVSE.	
⁽³⁾ If no MMQ is marked the maximum value shall be assumed.	

3.3 Accuracy requirements

3.3.1 General

The manufacturer shall specify the accuracy class of the EVSE to be one of A, B or C.

The EVSE shall be designed and manufactured such that its error does not exceed the maximum permissible error for the specified class under rated operating conditions.

The EVSE shall be designed and manufactured such that, when exposed to disturbances according to 3.3.5, critical faults do not occur.

Because of the nature of transactional testing, all tests contain transitional periods where the voltage and/or current are changing. Except during transitions between power levels, voltages and currents are typically slowly varying. As a result, no specific test with rapidly changing loads is present.

3.3.2 Direction of energy flow

Where a manufacturer has specified that an EVSE is capable of bidirectional energy flow, the EVSE shall correctly handle both positive and negative mean energy flow and shall fulfil the requirement of this Guide for energy flow in both directions. The polarity of energy flow shall be defined by the manufacturer's connection instructions for the EVSE. For AC EVSE, the mean energy flow refers to the instantaneous power integrated over at least one cycle of the nominal frequency.

An EVSE shall fall into at least one of the following categories:

- 1 Two-register, bidirectional: where the EVSE is specified as being capable of measuring both positive and negative mean energy flow, and where the positive result and negative result are placed in different registers. Energy registration shall occur in the correct register when the direction of flow changes.
- 2 Single-register, positive direction only: where the EVSE is specified as being capable of measuring and registering only positive mean energy flow. It may inherently, by its design, register only positive mean energy flow or it may be equipped with a reverse running detent. The manufacturer shall specify which method is used.

Note 1: The terms "single-register" and "two-register" in the list above refer to the basic energy register(s) only. An EVSE may have other registers, e.g. for storage of tariff and/or phase information.

Note 2: The national authority may determine what EVSE types and calculation methods are appropriate.

3.3.3 Base maximum permissible errors

The intrinsic error shall be within the base maximum permissible error stated in Table 2 for the specified current ranges when energy is at least MMQ and when the EVSE is otherwise operated at reference conditions.

Table 2 – Accuracy classes

Quantity		Base maximum permissible errors (%) for class		
Current, I	Power factor	A (2 %)	B (1 %)	C (0.5 %)
$I_{st} \leq I < I_{min}$	> 0.9	±25	±15	±10
$I_{min} \leq I < I_{tr}$	> 0.9	±2.5	±1.5	±1.0
$I_{tr} \leq I \leq I_{max}$	> 0.9	±2.0	±1.0	±0.5

Note: Electric vehicles are constrained by standards to operate at power factors of greater than 0.9.

3.3.4 Allowed effects of influence quantities

The temperature coefficient of the EVSE shall fulfil the requirements of Table 3 when the EVSE is otherwise operated at reference conditions.

Table 3 – Limits for temperature coefficient of error

Influence quantity	Limits for temperature coefficient (%/K) for EVSE of class		
	A (2 %)	B (1 %)	C (0.5 %)
Temperature coefficient, c , over any interval of the temperature range, which is not less than 15 K and not greater than 23 K, for current $I_{tr} \leq I \leq I_{max}$	±0.1	±0.05	±0.03
The test can be limited to only the extreme temperatures when the metrology is implemented by a separately approved meter whose type approval specifications meet or exceed those of this Guide.			

When the load current is held constant at a point within the rated operating range with the EVSE otherwise operated at reference conditions, and when any single influence quantity is varied from its value at reference conditions to its extreme values defined in Table 4, the variation of error shall be such that the additional percentage error is within the corresponding limit of error shift stated in Table 4. The EVSE shall continue to function after the completion of each of these tests. Validation is provided in 7.3.

Table 4 – Maximum permissible error shift due to influence quantities

Influence quantity	Value	Test	Current	Maximum permissible error shift (%) for EVSE of class		
				A (2 %)	B (1 %)	C (0.5 %)
Self-heating	Continuous current at I_{\max}	7.3.2	I_{\max}	±1	±0.5	±0.25
Voltage variation (AC EVSE only)	$0.9 \times U_{\text{nom}}$ to $1.1 \times \text{highest } U_{\text{nom}}$	7.3.4 †	$I_{\text{tr}} \leq I \leq I_{\max}$	±1.0	±0.7	±0.2
Frequency variation of mains AC EVSE only	Each $f_{\text{nom}} \pm 2 \%$	7.3.5 †	$I_{\text{tr}} \leq I \leq I_{\max}$	±0.8	±0.5	±0.2
Harmonics in voltage and current circuits ⁽¹⁾ AC EVSE only	$d < 5 \% I$ $d < 10 \% U$	7.3.6	$I_{\text{tr}} \leq I \leq I_{\max}$	±1.0	±0.6	±0.3
Reversed phase sequence (AC 3-phase only)	Any two phases interchanged	7.3.7 †‡	$I_{\text{tr}} \leq I \leq I_{\max}$	±1.5	±1.5	±0.1
Conducted disturbances, low frequency ⁽⁵⁾	2 kHz–150 kHz	7.3.10.2 †‡	$I_{\text{tr}} \leq I \leq I_{\max}$	±3.0	±2.0	±2.0
Continuous (DC) magnetic induction of external origin ⁽²⁾	200 mT at 30 mm from core surface ⁽²⁾	7.3.8	$I_{\text{tr}} \leq I \leq I_{\max}$	±3	±1.5	±0.75
Magnetic field (AC, power frequency) of external origin	400 A/m	7.3.9 †	$I_{\text{tr}} \leq I \leq I_{\max}$	±2.5	±1.3	±0.5
Radiated, RF, electromagnetic fields	$f = 80\text{MHz} - 6000\text{ MHz}$, Field strength $\leq 10\text{ V/m}$	7.3.10.1	$I_{\text{tr}} \leq I \leq I_{\max}$	±3	±2	±1
Conducted disturbances, induced by radio frequency fields ⁽³⁾	$f = 0.15\text{MHz} - 80\text{ MHz}$, Amplitude $\leq 10\text{ V}$	7.3.10.3 ‡	$I_{\text{tr}} \leq I \leq I_{\max}$	±3	±2	±1
Operation of ancillary devices ⁽⁴⁾	Ancillary devices operated with $I = I_{\text{tr}}$ and I_{\max}	7.3.11	$I_{\text{tr}} \leq I \leq I_{\max}$	±0.7	±0.3	±0.15

† These tests are not required for EVSE with a separately type approved meter if the type approval specifications meet or exceed those of this Guide.

‡ These tests are currently deemed not relevant in cases of DC EVSE where the influence will be filtered out by the AC to regulated DC conversion process.

(1) As long as the RMS value of the current is not higher than I_{\max} and the peak value of the current is not higher than $1.41 \times I_{\max}$.

(2) Manufacturers may additionally include an alarm upon detection of a continuous (DC) magnetic induction of greater than 200 mT. National authorities may select a lower magnetic induction for national requirements.

(3) Direct or indirect, conducted disturbances induced by radio-frequency fields.

(4) Only applicable to those ancillary devices which might be used (but are not required) during a charging session.

- ⁽⁵⁾ For DC EVSE, conducted interference in this frequency range is typically generated by the EVSE DC power supply. Therefore, it is always present any time a full system is performed.

3.3.5 Allowed effects of disturbances

3.3.5.1 General

The EVSE shall withstand disturbances that may be encountered under conditions of normal use, as stated in 3.3.1. No critical fault shall occur for any of the disturbances listed in Table 5, Table 6 and Table 7.

If an EVSE is operated under the conditions outlined in Table 5, Table 6 or Table 7 and no transaction is in progress, a change in the registers or pulses of the test output shall not be considered as a critical fault.

3.3.5.2 Electrical disturbances

The electrical disturbances tests can be performed either individually with an error check after each test or as a group with a single error check after all tests have been performed. An error shift larger than 1.0 BMPE shall not occur.

Table 5 – Electrical disturbances

Disturbance quantity	Ref.	Level of disturbance	Allowed effects
Electrostatic discharges	7.4.2	6 kV contact discharge 8 kV air discharge	No critical fault. No damage shall occur.
Fast transients	7.4.3 ‡	Voltage and current circuits: 2 kV Auxiliary circuits: 1.0 kV	No critical fault. No damage shall occur.
Voltage dips	7.4.4 ‡	Test a: 30 %, 0.5 cycles Test b: 60 %, 1 cycle Test c: 60 %, 25/30 cycles ⁽¹⁾	No critical fault.
Voltage interruptions	7.4.4 ‡	0 %, 250/300 cycles ⁽¹⁾	No critical fault.
Surges on AC mains power lines	7.4.5 †‡	Voltage circuits: 2 kV line to line, 4 kV line to earth Auxiliary circuits: 1 kV line to line, 2 kV line to earth	No critical fault. No damage shall occur.
Short-time overcurrent	7.4.6 †‡	$5 \times I_{\max}$ limited to a maximum of 3 kA	No critical fault. No damage shall occur.
Impulse voltage	7.4.7 ‡	1.5 kV for U ($100 \text{ V} \leq U < 150 \text{ V}$) 2.5 kV for U ($150 \text{ V} \leq U < 300 \text{ V}$) 4.0 kV for U ($300 \text{ V} \leq U < 600 \text{ V}$) 4.0 kV for U ($U \geq 600 \text{ V}$)	No critical fault. No damage shall occur.
⁽¹⁾ These values are for 50 Hz / 60 Hz, respectively. For DC cases, a duration of 5 s should be interpreted. † These tests are not required for EVSE with separately type approved meter if the type approval specifications meet or exceed those of this Guide. ‡ These tests are currently deemed not relevant in cases of DC EVSE where the disturbance will be filtered out by the AC to regulated DC conversion process.			

3.3.5.3 Environmental disturbances

The environmental disturbances tests can be performed either individually with an error check after each test or as a group with a single error check after all the tests have been performed. An error shift larger than 1.0 BMPE shall not occur.

Table 6 – Environmental disturbances

Disturbance quantity	Ref.	Level of disturbance	Allowed effects
Protection against solar radiation	7.4.8.1	0.76 W/m ² /nm at 340 nm, with cycling rig for 66 days.	No alteration in appearance or impairment in functionality, metrological properties and sealing.
Protection against ingress of dust	7.4.8.2	IP 5X, category 2 enclosure	No interference with correct operation or impairment of safety, including tracking along creepage distances.
Dry heat	7.4.8.3	One standard temperature higher than upper specified temperature limit, 2 h	No critical fault.
Cold	7.4.8.4	One standard temperature lower than lower specified temperature limit, 2 h	No critical fault.
Damp heat	7.4.8.5, 7.4.8.6	H1: 30 °C, 85 %; H2: Cyclic 25 °C, 95 % to 40 °C, 93 %; H3: Cyclic 25 °C, 95 % to 55 °C, 93 %.	No critical fault. No evidence of any mechanical damage or corrosion.
Water	7.4.8.7	H3 only: 0.07 L/min (per nozzle), 0 ° and 180 °, 10 min	No critical fault. No evidence of any mechanical damage or corrosion.
<i>Note:</i> For complex DC EVSE, these tests should be applied to the console only.			

3.3.6 Mechanical disturbances

Mechanical disturbances are intended to simulate conditions encountered during transportation. National authorities may eliminate any of these requirements when the EVSE is too large to perform the associated test reasonably and at a reasonable cost. These requirements may also be eliminated from type approval if *in situ* testing is performed prior to an EVSE being put into service.

Table 7 – Mechanical disturbances

Disturbance quantity	Ref.	Level of disturbance	Allowed effects
Vibration	7.4.10.1	Vibration in three mutually perpendicular axes.	No critical fault. Function of the EVSE shall not be impaired.
Shock	7.4.10.2	Pulse shape: Half-sine Peak acceleration: 30 g _n Pulse duration: 18 ms.	No critical fault. Function of the EVSE shall not be impaired.
<i>Note:</i> These tests should be applied to unitary EVSE and to the console of complex DC EVSE.			

3.4 Durability

The EVSE shall be designed to maintain an adequate stability of its metrological characteristics over a reverification period specified by the national authority or eight years if none is specified, provided it is properly installed, maintained and used according to the manufacturer's instructions when in the environmental conditions for which it is intended.

The EVSE shall be designed to reduce as far as possible the effect of a defect that would lead to an inaccurate measurement result.

The EVSE shall be designed and manufactured such that either:

- a) Significant durability errors do not occur, or
- b) Significant durability errors are detected and acted upon by means of a durability protection.

Durability shall be tested according to the specifications provided in 7.4.9.

Note: National authorities may accept alternative methods to show compliance with the requirement, such as mean time before failure (MTBF) calculations or other reliability data from manufacturers in lieu of this test.

4 Functional requirements

4.1 Markings

National authorities shall determine what information shall be marked on every EVSE. The EVSE shall have a clearly visible nameplate and the following are strongly recommended as minimum markings:

- approval mark;
- approval number/identifier;
- manufacturer;
- year of manufacture;
- manufacturer model;
- serial number;
- voltage range (minimum and maximum output voltage);
- current range (starting current, minimum current, transitional current and maximum current);
- frequency;
- temperature range;
- accuracy class; and
- MMQ (minimum measurement quantity).

The markings shall be indelible, distinct and legible from outside the EVSE. The markings of EVSE intended for outdoor locations shall withstand solar radiation.

If the serial number is affixed to dismountable parts, the serial number shall also be provided in a position where it is not readily disassociated from parts determining the metrological characteristics.

Symbols or their equivalent may be used where appropriate. See e.g. IEC 62053-52, 6.4, or other designations accepted by local jurisdictions.

4.2 Suitability for use

4.2.1 General

4.2.1.1 An EVSE shall fulfil all requirements in this Guide. This includes all the metrological requirements and the requirements on software and the internal clock (if applicable).

Note 1: Additionally, national authorities may specify requirements to measure the total energy supplied to the EVSE.

Note 2: National authorities may require additional legally relevant information to be made accessible to the end user, such as time and date, customer ID, station ID, meter ID.

4.2.1.2 Accuracy shall be determined at the connection point to the vehicle (reference D in Figure 1 and Figure 2).

4.2.1.3 An EVSE that applies corrections to compensate for energy loss introduced by parts comprising a cable and connector mounted between the position at which the energy is measured and the connecting point shall either

- a) Ensure those parts are not replaceable and secured by an appropriate hardware seal; or
- b) If the parts are intended to be replaceable while the EVSE is under seal, the replacement parts shall comply with the following:
 - i) they shall be identical in every respect to the originally verified parts;
 - ii) they shall be identified on the type approval certificate as replaceable;
 - iii) they shall include as a minimum the following markings readily viewable and located on the parts or assembly, if parts are combined:
 - approval number/identifier;
 - manufacturer's name or trademark;
 - manufacturer model;
 - any other relevant marking as needed to distinguish between similar unapproved devices.
 - iv) The above markings must also be documented in the type approval certificate.

Note: National authorities may choose to allow only case a).

4.2.1.4 The EVSE shall have no means to allow measured energy to be diverted between the point of measurement and the EV.

4.2.1.5 If an EVSE is capable of receiving electrical energy from the vehicle to be transferred to the nominal source, then:

- a) the client interface shall be able to display all the necessary information related to the transactions in both directions;
- b) the EVSE shall be of the “two-register, bidirectional” category, as defined in 3.3.2 of this Guide;
- c) the accuracy requirements shall be fulfilled for both directions; and
- d) all the metrological and functional requirements from clauses 3 and 4 shall also be applicable to this kind of transaction.

4.2.2 Transactions

4.2.2.1 Legally relevant transaction data

National authorities shall determine what information must be provided for each transaction. Suggested practice for the three types of transaction are given below.

4.2.2.1.1 Ad hoc public transactions

Ad hoc public transactions are defined in 2.2.16.1.

Required:	Measured energy delivered to the EV
	Measured energy received from the EV (if appropriate)
	Unit price
	Total transaction cost
	If multiple tariffs are used, for each occurrence of each different tariff
	<ul style="list-style-type: none"> ▪ Unit price; ▪ Measured energy at this tariff; ▪ Start time; ▪ End time; ▪ Cost at this tariff.
Recommended:	Customer identifier
	Time and date
	Vendor identifier
	EVSE identifier

4.2.2.1.2 Contractual public transactions

Contractual public transactions are defined in 2.2.16.2.

Required:	Measured energy
	If multiple tariffs are used, for each occurrence of each different tariff
	<ul style="list-style-type: none"> ▪ Measured energy at this tariff.
Recommended:	Unit price
	Total transaction cost
	If multiple tariffs are used, for each occurrence of each different tariff

- Unit price;
- Start time;
- End time;
- Cost at this tariff.

Customer identifier

Time and date

Vendor identifier

EVSE identifier

4.2.2.1.3 Contractual private transactions

Contractual private transactions are defined in 2.2.16.3.

Required: Total energy measured for the billing period

4.2.2.2 Availability of legally relevant transaction data

Legally relevant data referenced in 4.2.2.1 must be stored in the EVSE and available for display to the user until it has been transmitted for settlement and an acknowledgement received.

Note: National authorities may require that the legally relevant data is stored inside the EVSE. For externally stored data, national authorities may also impose specific requirements on data security.

4.2.2.3 Completing transaction at connection break

Means shall be provided to automatically terminate charging and complete the transaction in the event of a break in the connection with the vehicle. Any legally relevant data associated with the transaction shall be handled as though the transaction had been completed normally.

Note: The minimum storage period for legally relevant data shall be determined by national authorities.

4.2.3 Multiple tariffs

An EVSE that can apply multiple tariffs during an energy transfer session shall meet the following requirements:

- 1) the price applied shall not change during a transaction unless approved in advance by the user;
- 2) they shall be able to measure and store all data relevant for billing;
- 3) the sum of all energy registered in multi-tariff registers shall be equal to the total energy transferred during the transaction;
- 4) only one register can be active at any one time during a transaction;
- 5) for ad hoc transactions, it shall be clear for each part of the transaction:
 - a) the amount of energy transferred;
 - b) the time interval over which the energy was transferred;
 - c) the direction of the energy transfer, if applicable; and
 - d) the unit price that was applied.

Multiple tariffs shall not be applied unless the customer has agreed to variable pricing through interaction with the EVSE or a contractual agreement.

4.2.4 Power outage

In the event of a supply power outage:

- 1) the transaction shall be paused at the time of the supply power outage;
- 2) once power is restored:
 - a) if the EVSE is able to determine it is connected to the same vehicle before and after the supply power outage, the EVSE may continue charging without additional authorisation and the transaction that was in process can complete normally;
 - b) if the EVSE is not able to determine it is connected to the same vehicle before and after the supply power outage, the EVSE shall terminate the transaction at the point that the power failed:
 - i) the EVSE may abandon the charging session with no charge to the customer; or
 - ii) the EVSE may complete the transaction, charging the customer for only the services provided up to the point of power failure. In this case all the requirements for a completed transaction apply;
 - c) if a transaction cannot be resumed after a power failure, then once power is restored the information from the last transaction shall be displayed for 15 min, or until the next transaction begins, whichever comes first.

4.3 Access to data

4.3.1 Readability of the result

An EVSE shall make the legally relevant transaction data accessible to the end user through the client interface. This shall be done in accordance with 4.3.1.1 and/or 4.3.1.2. Both options may be implemented.

4.3.1.1 The EVSE is provided with an indicating device that is locally visible from the outside of the EVSE and that is capable of showing the legally relevant transaction data as indicated in 2.3.38, with a minimum character height of 4 mm.

4.3.1.2 The EVSE is provided with a non-local client interface to provide the end user access to the data, where the following minimum requirements shall be fulfilled:

- a) the EVSE is provided with communication means to send out all necessary legally relevant transaction data as indicated in 2.3.38;
- b) all transported legally relevant transaction data is secured by the EVSE, by state-of-the-art cryptographic means;
- c) the legally relevant transaction data shall be made accessible to the end user together with all the information required to check the authenticity, using fit for purpose technical means, which are not part of the EVSE.

Note 1: National authorities may decide whether a local physical client interface according to 4.3.1.1 is mandatory, or whether the solution according to 4.3.1.2 can be allowed, or whether additional requirements are needed.

Note 2: Examples of appropriate to application cryptographic means are published by institutes such as NIST, BSI, etc. These means may be e.g. AES data in 128-bit blocks using 128, 192 or 256 bit. OIML D 31:2019 *General requirements for software controlled measuring instruments* [2] includes information on the application of cryptographic means to software and data transmission in legal metrology.

4.3.2 Client interfaces

The following requirements apply to all client interfaces:

- they shall be able to display all data relevant for billing purposes in an easily readable form;
- they shall display the energy being transferred, either continuously or on demand;
- they shall provide facilities to allow any user input relevant to a transaction;
- for multi-tariff devices, the data for each tariff applied shall be displayed;
- any decimal fractions shall be clearly indicated;
- they shall not be significantly affected by exposure to normal operating conditions over the maximum duration of the EVSE lifetime.

4.3.3 Registers

Electronic registers shall be non-volatile so that they retain stored values upon loss of power. Stored values shall not be overwritten and shall be capable of being retrieved upon restoration of power. The register shall be capable of storing and displaying an amount of energy sufficient to ensure that no roll over will occur during a transaction. This capability for storage and display applies to all registers relevant for billing including positive and negative flow registers for bidirectional EVSE and tariff registers for multi-tariff EVSE.

Note: The national authority may set the energy required for register rollover.

In the case of electronic registers, the minimum retention time is until the transaction is finalised or cancelled. If electronic indicating devices have segments, then the EVSE shall be provided with a display test that switches all the display segments on then off for the purpose of determining whether all the display segments are working.

The EVSE shall have one or more registers for the energy delivered to the electrical vehicle for a transaction, which shall be reset to zero at the beginning of a new transaction. The reset to zero function shall be disabled while a charging event is ongoing.

4.3.4 Testability

4.3.4.1 The EVSE shall readily provide legally relevant energy data to the evaluator with the resolution specified in 4.3.4.1.1 or 4.3.4.1.2 or better, where the least significant digit increments by 1, without any additional means.

Note: These resolutions are required in order to allow testing to be done within a reasonable amount of time.

4.3.4.1.1 An AC EVSE shall be capable of providing test results with a resolution better than 0.0001 kWh (0.1 Wh).

4.3.4.1.2 A DC EVSE shall be capable of providing test results with a resolution better than 0.001 kWh (1.0 Wh).

4.3.4.2 For ad hoc transactions the EVSE shall provide the price per unit of measurement and the total money value of the transaction.

4.3.4.3 The primary mode of testing shall be based on the energy displayed on the client interface of the EVSE. Transaction data should be read directly from the client interface or from the cryptographic secured data-package of the legally relevant data, via a communication interface.

If present, testing may also be performed while using a dedicated pulse output. The pulse output shall conform to the following:

- 4.3.4.3.1 The energy per pulse shall be no greater than the resolution of the client interface.
- 4.3.4.3.2 There is a clear relationship between the pulse output and the indication on the client interface. Specifically, the energy represented by the pulse train during a transaction shall agree with that displayed on the client interface within ± 1 least significant digit.
- 4.3.4.3.3 The characteristics of the optical output shall conform to the following:
- 1) The wavelength of the radiated signals for emitting systems shall be between 550 nm and 1000 nm.
Note: In outdoor circumstances exposed to sunlight, detecting pulse signals at infrared wavelengths (>800 nm) is likely to be easier than at optical wavelengths.
 - 2) The optical output in the EVSE shall generate a signal with a radiation strength, E_T , over a reference surface (optically active area) at a distance of $10 \text{ mm} \pm 1 \text{ mm}$ from the surface of the EVSE, with the following limiting values:

ON-condition:	$250 \mu\text{W}/\text{cm}^2 \leq E_T \leq 7\,500 \mu\text{W}/\text{cm}^2$
OFF-condition:	$E_T \leq 2 \mu\text{W}/\text{cm}^2$
 - 3) The existence of a pulse output does not eliminate the requirements of 4.3.4.1 and 4.3.4.2.

4.4 Protection of metrological properties

4.4.1 General

An EVSE shall be provided with the means to protect its metrological properties. National authorities shall determine levels of authorised access for software protection (4.4.3), parameter protection (4.4.4) and checking facility event record (4.4.8).

4.4.2 Software identification

Legally relevant software of an EVSE shall be clearly identified with the software version or another token. The identification may consist of more than one part but at least one part shall be dedicated to the legal purpose. The identification shall be inextricably linked to the software itself and shall be presented on command or displayed during operation. It is permissible to have more than one legally relevant software part, however each legally relevant software part shall be identified.

As an exception, an imprint of the software identification on the EVSE shall be an acceptable solution if it satisfies all the following conditions:

- a) The user interface does not have any control capability to activate the indication of the software identification on the display, or the display does not technically allow the identification of the software to be shown;
- b) After production of the EVSE a change of the software is not possible, or only possible if the hardware or a hardware component is also changed.

Note: The manufacturer of the hardware or the concerned hardware component is responsible for ensuring that the software identification is conspicuously and correctly marked on the EVSE.

The software identification and the means of identification shall be stated in the type approval certificate.

4.4.3 Software protection

4.4.3.1 Prevention of misuse

An EVSE shall be constructed in such a way that possibilities for unintentional, accidental, or intentional misuse are minimal.

4.4.3.2 Fraud protection

4.4.3.2.1 Legally relevant software shall be protected in such a way that evidence of any intervention (e.g. software updates, parameters changes) shall be available. Updates to legally relevant software or legally relevant parameters are permitted if the EVSE complies with the requirements of 4.4.7. Legally relevant software shall be secured against unauthorised modification, loading, or changes by swapping the memory device. Mechanical sealing or other technical means may be necessary to secure the EVSE. Audit trails are considered to be part of the legally relevant software and shall be protected as such.

4.4.3.2.2 Only clearly documented functions (see 4.1) are allowed to be activated by the user interface, which shall be realised in such a way that it does not facilitate fraudulent use.

4.4.3.2.3 Software protection shall comprise appropriate sealing by mechanical, electronic and/or cryptographic means, making an intervention impossible or evident.

Examples:

- a) The software of a measuring instrument is constructed such that there is no way to modify the parameters and legally relevant configuration but via a switch-protected menu. This switch is mechanically sealed in the inactive position, rendering modification of the parameters and of the legally relevant configuration impossible. To modify the parameters and configuration, the switch has to be switched, inevitably breaking the seal by doing so.
- b) The software of a measuring instrument is constructed such that there is no way for unauthorised persons to access the parameters and legally relevant configuration. The access is recorded in an audit trail including the identity of the person (the means of identification used, e.g. a smart card).

Note: As an example, if a person wants to enter the parameter menu item a smart card containing a PIN as part of a cryptographic certificate could be used. The software of the instrument must be able to verify the authenticity of the PIN by the certificate and allows the parameter menu item to be entered.

4.4.4 Parameter protection

Parameters that fix the legally relevant characteristics of the EVSE shall be secured against unauthorised modification. If necessary for the purpose of verification, the current parameter settings shall be capable of being displayed.

Device-specific parameters may be adjustable or selectable only in a special operational mode of the EVSE. They may be classified as those that shall be protected (unalterable) and those that may be accessed (settable parameters) by an authorised person, e.g. the instrument owner or repairer.

National regulations may prescribe that certain device-specific parameters, e.g. price per kWh, may be available to the instrument owner. In such a case, the EVSE shall be fitted with a facility to automatically and non-eraseably record any adjustment of the device-specific parameter, e.g. an audit trail. The instrument shall be capable of presenting the recorded data.

The traceability means and records are part of the legally relevant software and shall be protected as such. The software employed for displaying the audit trail belongs to the fixed legally relevant software.

National authorities may require an additional totalising register, which cannot be reset without breaking a metrological seal (physical and/or digital seal). Zeroing the totalising register that stores the total energy of all metered transactions shall be considered as a modification of a device-specific parameter. Therefore, all relevant requirements applicable to device-specific parameters are applicable to the zeroing operation.

It shall not be possible to make any modifications to parameters during a transaction.

4.4.5 Separation of electronic devices and sub-assemblies

Legally relevant parts of an EVSE – whether software or hardware parts – shall not be inadmissibly influenced by other parts of the EVSE.

4.4.5.1 Sub-assemblies or electronic devices of an EVSE that perform legally relevant functions shall be identified, clearly defined, and documented. They form the legally relevant part of the measuring system. If the sub-assemblies that perform legally relevant functions are not identified, all sub-assemblies shall be considered to perform legally relevant functions.

Example: An EVSE is equipped with a WiFi interface for connecting an electronic device to read out measurement values. The EVSE stores all the relevant quantities and keeps the values available for being read out until the transaction is finalised. In this system only the EVSE is the legally relevant device. Other legally non-relevant devices may exist and may be connected to the interface of the instrument provided the requirement in 4.4.5.2 is fulfilled. Securing of the data transmission itself (see 4.4.9) is not required.

4.4.5.2 During type testing, it shall be demonstrated that the relevant functions and data of sub-assemblies and electronic devices cannot be inadmissibly influenced by commands received via the interface.

This implies that there is an unambiguous assignment of each command to all initiated functions or data changes in the sub-assembly or electronic device.

Note: If legally relevant sub-assemblies or electronic devices interact with other legally relevant sub-assemblies or electronic devices, refer to 4.4.9.

Example a): The software of the EVSE (see example in 4.4.5.1, above) is able to receive commands for selecting the quantities required. It combines the measurement value with additional information – e.g. time stamp, EVSE ID – and sends this data set back to the requesting device. The software only accepts commands for the selection of valid allowed quantities and discards any other command, sending back only an error message. There may be securing means for the contents of the data set, but they are not required, as the transmitted data set is not subject to legal control.

Example b): Inside the housing that can be sealed there is a switch that defines the operating mode of the EVSE: one switch setting indicates the verified mode and the other the non-verified mode (securing means other than a mechanical seal are possible; see examples in 4.4.3.2.3. When interpreting received commands, the software checks the position of the switch: in the non-verified mode the command set that the software accepts is extended compared to the mode described above; e.g. it may be possible to adjust the calibration factor by a command that is discarded in the verified mode.

4.4.6 Separation of software parts

4.4.6.1 All software modules (programs, subroutines, objects, etc.) that perform legally relevant functions or that contain legally relevant data domains form the legally relevant software part of an EVSE. They shall be made identifiable as described in 4.4.2. If the software modules that perform legally relevant functions are not identified, the whole software shall be considered as legally relevant.

4.4.6.2 If the legally relevant software part communicates with other software parts, a software interface shall be defined. All communication shall be performed exclusively via this interface. The legally relevant software part and the interface shall be clearly documented. All legally relevant functions and data domains of the software shall be described to enable a type approval authority to decide on correct software separation.

4.4.6.3 The software interface consists of program code and dedicated data domains. Defined coded commands or data are exchanged between the software parts by storing to the dedicated data domain by one software part and reading from it by the other. Writing and reading program code is part of the software interface.

4.4.6.4 There shall be an unambiguous assignment of each command to all initiated functions or data changes in the legally relevant part of the software. Commands that communicate through the software interface shall be declared and documented. Only documented commands are allowed to be activated through the software interface. The manufacturer shall state the completeness of the documentation of commands.

4.4.7 Updates to legally relevant software

Updating the legally relevant software of an EVSE in the field should be considered as:

- a modification of the EVSE, when exchanging the software with another approved version;
- a repair of the EVSE, when re-installing the same version.

An EVSE which has been modified or repaired while in service may require initial or subsequent verification, dependant on national regulations.

An update of the legally relevant software shall be either a verified update (4.4.7.1) or a traced update (4.4.7.2).

National authorities may prescribe that the software update mechanism is disabled by means of a sealable setting (physical switch, secured parameter) where software updates for instruments in use are not allowed. In this case it shall not be possible to update legally relevant software without breaking the seal.

Legally non-relevant software of the EVSE does not require verification after being updated.

Note: Separation of legally relevant and legally non-relevant software parts is possible, as described in 4.4.6.

Only versions of legally relevant software that conform to the approved type are allowed for use.

4.4.7.1 Verified update

The software to be updated can be loaded locally, i.e., directly on the measuring device, or remotely via a network. Loading and installation may be two different steps or combined into one, depending on the needs of the technical solution. After the update of the legally relevant software of an EVSE (exchange with another approved version or re-installation) the EVSE is not allowed to be employed for legal purposes before a verification of the instrument has been performed and the securing means have been renewed.

4.4.7.2 Traced update

The software is implemented in the instrument according to the requirements for Traced Update (4.4.7.2.1 to 4.4.7.2.7). A traced update is the procedure of changing software in a verified instrument or device after which the subsequent verification by a responsible person on site is not necessary. The software to be updated can be loaded locally, i.e., directly on the measuring device or remotely via a network. The software update is recorded in an audit trail. The procedure for a traced update comprises several steps: loading, integrity checking, checking of the origin (authentication), installation, logging and activation.

- 4.4.7.2.1 Traced update of software shall be automatic. On completion of the update procedure the software protection environment shall be at the same level as required by the type approval.
- 4.4.7.2.2 The target EVSE shall have fixed legally relevant software that cannot be updated and that contains all of the checking functions necessary for fulfilling traced update requirements.
- 4.4.7.2.3 Technical means shall be employed to guarantee the authenticity of the loaded software, i.e., that it originates from the owner of the type approval certificate. If the loaded software fails the authenticity check, the instrument shall discard it and use the previous version of the software or switch to an inoperable mode.
- 4.4.7.2.4 Technical means shall be employed to ensure the integrity of the loaded software, i.e., that it has not been inadmissibly changed before loading. This can be accomplished by adding a checksum or hash code of the loaded software and verifying it during the loading procedure. If the loaded software fails this test, the instrument shall discard it and use the previous version of the software or switch to an inoperable mode. In this mode, the measuring functions shall be inhibited. It shall only be possible to resume the download procedure, without omitting any steps in the process for traced update.
- 4.4.7.2.5 Appropriate technical means, e.g. an audit trail, shall be employed to ensure that traced updates of legally relevant software are adequately traceable within the instrument for subsequent verification and surveillance or inspection.

The audit trail shall contain at minimum the following information: success/failure of the update procedure, software identification of the installed version, software identification of the previous installed version, time stamp of the event, identification of the downloading party. An entry shall be generated for each update attempt regardless of the success.

The storage device that supports the Traced Update shall have sufficient capacity to ensure the traceability of traced updates of legally relevant software between at least two successive verifications in the field or inspection. After having reached the limit of the storage for the audit trail, it shall be ensured by technical means that further downloads are impossible without breaking a seal.

Note: This requirement enables inspection authorities, which are responsible for the metrological surveillance of legally controlled instruments, to back-trace traced updates of legally relevant software over an adequate period of time (depending on national legislation).

- 4.4.7.2.6 Depending on the needs and on national legislation it may be necessary for the owner of the EVSE to give their consent to a traced update. The EVSE shall have a feature for the owner to express their consent, e.g. a push button, before the update starts. It shall be possible to enable and disable this feature, e.g. by a switch that can be sealed or by a parameter. If this feature is enabled, each traced update needs to be initiated by the owner. If it is disabled, no activity by the owner is necessary to perform a traced update.
- 4.4.7.2.7 If the requirements in 4.4.7.2.1–4.4.7.2.6 cannot be fulfilled, it is still possible to update the legally non-relevant software part. In this case the following requirements shall be met:
- the software shall comply with the requirements of 4.4.6 such that there is a distinct separation between the legally relevant and non-relevant software;
 - the whole legally relevant software part cannot be updated without breaking a seal.

It is stated in the type approval certificate that updating of the legally non-relevant part is acceptable.

4.4.8 Checking facility event record

If the EVSE is equipped with a checking facility, the event record of the facility shall have room for at least 100 events (or an alternative number determined by the national authority) and shall be of a first-in-first-out type. It shall not be possible to change or zero the event record without breaking a seal and/or without authorised access, for example by means of a code (password) or of a special device (hard key, etc.).

Note: The checking facility event log is not the same as the audit trail (see 4.4.7.2.5).

4.4.9 Storage of data, transmission via communication systems

4.4.9.1 General

If measurement values are used at another place than the place of measurement or at a later time than the time of measurement, they possibly have to leave the EVSE (electronic device, sub-assembly) and be stored or transmitted in an insecure environment before they are used for legal purposes. In this case the following requirements apply:

4.4.9.1.1 The measurement value stored or transmitted shall be accompanied by all relevant information necessary for future legally relevant use.

4.4.9.1.2 The legally relevant data shall be protected by software and/or hardware encryption means to guarantee the authenticity, integrity and, if necessary, correctness of the information concerning the time of measurement. The software that displays or further processes the measurement values and accompanying data shall check the time of measurement, authenticity, and integrity of the data after having read them from the insecure storage or after having received them from an insecure transmission channel. If an irregularity is detected, the data shall be discarded or marked unusable.

Note: The flexible management and control mechanism of key storage and generation and the dynamic application mechanism of one key at a time are deemed to be an acceptable solution.

Private keys employed for protecting data shall be kept secret and secured in the EVSE. Means shall be provided whereby these keys can only be input or read if a seal is broken.

4.4.9.1.3 Software modules that prepare data for storing or sending, or that check data after reading or receiving, belong to the legally relevant software part.

4.4.9.2 Automatic storing

4.4.9.2.1 When data storage is required, measurement data must be stored automatically when the measurement is concluded, i.e., when the final value has been generated. When the final value is from a calculation, all data that are necessary for the calculation must be automatically stored with the final value.

4.4.9.2.2 The storage device must have sufficient permanency to ensure that the data are not corrupted under normal storage conditions. There shall be sufficient memory storage for any particular application.

4.4.9.2.3 Stored data may be deleted if the transaction is settled.

Note: This shall not apply to the cumulative register and audit trail.

4.4.9.3 Data transmission

4.4.9.3.1 The measurement shall not be inadmissibly influenced by a transmission delay.

4.4.9.3.2 If network services become unavailable, no legally relevant measurement data shall be lost.

4.4.9.4 Time stamps

Time stamps used in transactions shall be accurate to ± 60 s with respect to legal time.

Note 1: National jurisdictions may establish criteria for an appropriate time reference for 'legal time'.

Note 2: National jurisdictions may establish more stringent accuracy requirements.

Part 2

Metrological controls and performance tests

5 Type approval

5.1 Documentation

The documentation submitted with the application for type approval shall include:

- identification of the type, including
 - name or trademark and type designation;
 - version(s) of hardware and software;
 - drawing of name plate.
- metrological characteristics of the EVSE, including
 - description of the principle(s) of measurement;
 - metrological specifications such as accuracy class and rated operating conditions (3.1);
 - any steps which should be performed prior to testing the EVSE.
- the technical specification for the EVSE, including
 - block diagram with a functional description of the components and devices;
 - drawings, diagrams and general software information, explaining the construction and operation, including interlocks;
 - description and position of seals or other means of protection;
 - documentation related to durability characteristics;
 - any document or other evidence that the design and construction of the EVSE complies with the requirements of this Guide;
 - specified clock frequencies;
- user manual;
- installation manual;
- description of the checking facility for critical faults, if applicable.

In addition, software documentation shall include:

- description of the legally relevant software and how the requirements are met:
 - list of software modules that belong to the legally relevant part including a declaration that all legally relevant functions are included in the description;
 - description of the software interfaces of the legally relevant software part and of the commands and data flows via this interface including a statement of completeness;
 - description of the generation of the software identification;
 - description of the software update mechanism;
 - list of parameters to be protected and description of protection means.
- description of security means of the operating system (password, etc. if applicable);
- description of the (software) sealing method(s);
- overview of the system hardware, e.g. topology block diagram, type of computer(s), type of network, etc.;
- where a hardware component is deemed legally relevant or where it performs legally relevant functions, this should also be identified;

- description of the accuracy of the algorithms (e.g. filtering of A/D conversion results, price calculation, rounding algorithms, etc.);
- description of the user interface, menus and dialogues;
- software identification and instructions for obtaining it from an instrument in use;
- list of commands of each hardware interface of the measuring instrument / electronic device / sub-assembly including a statement of completeness;
- list of durability errors that are detected by the software and if necessary for understanding, a description of the detecting algorithms;
- description of data sets stored or transmitted;
- if fault detection is realised in the software, list of faults that are detected and a description of the detecting algorithm;
- operating manual.

Furthermore, if the type approval is partially based on existing type test documentation (such as approval of a meter or safety testing), the application for type approval shall be accompanied by type test documents or other evidence that supports the assertion that the design and characteristics of the measuring instrument comply with the requirements of this Guide.

5.2 Type definition

EVSE produced by the same manufacturer may form a type, provided they have similar metrological properties resulting from the use of the same uniform construction of parts/modules that determine the metrological properties.

A type may have several current ranges and several values of the nominal voltage and frequency, and include several connection modes and several ancillary devices.

Note: The same uniform construction normally means the same construction of the measuring elements, the same construction of metering software, the same construction of the register and indicating device, the same temperature compensation mechanism, the same construction of case, terminal block, and mechanical interface.

5.2.1 Type test sampling

The manufacturer shall provide at least as many specimens of the EVSE as are required by the national authority. The type test shall be made on one or more specimens of the EVSE, selected by the type test body, to establish its specific characteristics and to prove its conformity with the requirements of this Guide. In the case of modifications to the EVSE made after or during the type test and affecting only part of the EVSE, the issuing body may deem it sufficient to perform limited tests on the characteristics that may be affected by the modifications.

5.3 Software validation procedure

The software validation procedure consists of a combination of analysis methods and tests as shown in Table 8. The abbreviations used are described in Table 9.

Table 8 – Validation procedures for specified requirements

Requirement		Validation procedure
4.4.2	Software identification	AD + VFTSw
4.4.3.1	Prevention misuse	AD + VFTSw
4.4.3.2	Fraud protection	AD + VFTSw
4.4.4	Parameter protection	AD + VFTSw
4.4.5	Separation of electronic devices and sub-assemblies	AD
4.4.6	Separation of software parts	AD
4.4.7	Updates to legally relevant software	AD + VFTSw
4.4.8	Checking facility event record	AD
4.4.9	Storage of data, transmission via communication systems	AD + VFTSw

Table 9 – Validation procedure abbreviations

Abbreviation	Description	OIML D 31:2008 clause
AD	Analysis of the documentation and validation of the design	6.3.2.1
VFTSw	Validation by functional testing of software functions	6.3.2.3

6 Test programme

EVSE testing is done using the same transactional process as is used in normal operation of the EVSE. This process consists of at least the following steps:

- 1) Initiating a charging session using the standard handshake exchange between the EVSE and a vehicle. For test purposes, a vehicle may be replaced by a simulated vehicle, as long as it conforms to the usual protocols for handshake exchange.
- 2) Charging at a specified power level for a specified quantity of energy (must be greater than the MMQ).
- 3) Terminate the transaction normally using the vehicle to EVSE communications protocol.
- 4) Compare the energy delivered and – for ad hoc transactions – the transaction cost provided by the EVSE with the measured energy of the reference standard and the cost computed based on that energy.

Note 1: For a DC EVSE, the energy delivered should be sufficient so that the amount of energy delivered during ramp up and ramp down are less than 10 percent of the energy delivered at the test power.

Note 2: The tests can be performed either with a real load or with a phantom load.

The initial intrinsic error shall be determined as the first test on the EVSE, as described in 7.2.1.

Power shall be applied to the EVSE for a period of 15 min before the start of testing

The order of the test points for initial intrinsic error shall be from lowest current to highest current and then from highest current to lowest current at each nominal voltage, beginning at the lowest and proceeding to the highest. For a DC EVSE, the test shall be run from the minimum output voltage to the maximum output voltage. For each test point, the resulting error shall be the mean of these measurements. In each case the minimum measured quantity of energy shall be delivered.

The determination of the initial intrinsic error (at reference conditions) shall always be carried out before tests of influence quantities and before disturbance tests that relate to a limit of error shift requirement or to a critical fault condition for error.

Otherwise, the order of tests is not prescribed in this Guide.

If an EVSE is specified for both single-phase and three-phase operation, then both configurations shall be tested.

For the purposes of the tests for DC EVSE the DC reference meter shall only measure energy up to 2 kHz.

National authorities may prescribe more stringent test regimes than those described in this section.

7 Test procedures for type approval

7.1 Test conditions

Unless otherwise stated in the individual test instructions, all influence quantities except for the influence quantity being tested shall be held at reference conditions as given by Table 10 during type approval tests.

Table 10 – Reference conditions for type approval testing

Quantity	Reference conditions	Tolerance
Voltage(s) AC EVSE DC EVSE	Highest U_{nom} 375 ± 50 VDC and 750 ± 50 VDC	±1 % N/A
Ambient temperature	23 °C ⁽¹⁾	±2 °C
Frequency AC EVSE DC EVSE	f_{nom} DC	±0.3 % N/A
Waveform (U and I) AC EVSE DC EVSE	Sinusoidal DC	$d \leq 2 \%$ N/A
Magnetic induction of external origin at reference frequency	0 T	$B \leq 0.05 \text{ mT}$
Electromagnetic RF fields 30 kHz to 6 GHz	0 V/m	$\leq 1 \text{ V/m}$
Operating position for instruments sensitive to position	Mounting as stated by manufacturer	±3.0°
Load balance (3-phase AC EVSE) ⁽²⁾	Equal current in all current circuits	±2 %

(1)	Tests may be performed at other temperatures if the results are corrected to the reference temperature by applying the temperature coefficient established in the type tests and provided an appropriate uncertainty analysis is carried out.
(2)	The requirement applies to both phase-to-phase and phase-neutral for poly-phase EVSE.
<i>Note:</i>	The reference conditions and their tolerance are given to ensure reproducibility between testing laboratories, not to determine the accuracy of the tests. The demands on short term stability during testing for influence factors may be much higher than shown in this table.

Table 11 – Load conditions and their tolerances in tests

Quantity	Conditions	Tolerance
Current	Current range of device under test	Class A, B: $\pm 2\%$ Class C: $\pm 1\%$
Power factor (AC EVSE ONLY)	Power factor range of device under test	Current to voltage phase difference: $\pm 2^\circ$
<i>Note:</i>	The load conditions and their tolerance are given to ensure reproducibility between testing laboratories, not to determine the accuracy of the tests. The demands on short time stability during testing for influence factors may be much higher than shown in this table.	

7.2 Tests for compliance with maximum permissible errors

7.2.1 Determination of initial intrinsic error

Object of the test: To verify that the error of the EVSE at reference conditions is less than the relevant BMPE given in Table 2.

Test procedure: An EVSE that is specified as being capable of bidirectional or unidirectional energy measurement as described in 3.3.2 shall meet the relevant BMPE requirements of Table 2 for energy flow in both positive and negative directions.

Mandatory test points:

AC EVSE: Tests shall be conducted at unity power factor at I_{\min} , I_{tr} , $50\% I_{\max}$ and I_{\max} for a delivered energy of at least the minimum measured quantity at each U_{nom} . If an EVSE is rated for multiple frequencies it shall be tested at all nominal frequencies.

DC EVSE: Tests shall be conducted at I_{\min} , I_{tr} , $50\% I_{\max}$ and I_{\max} for a delivered energy of at least the minimum measured quantity at U_{\min} , U_{\max} , and the midpoint between. The total quantity of energy delivered shall be sufficient such that at least 90 % of the energy delivered is delivered at intended level.

7.2.2 Starting current

Object of the test: To verify that the EVSE starts and continues to operate at I_{st} as given by Table 1.

Test procedure: The EVSE shall be subjected to a current equal to the starting current I_{st} for a delivered energy of the minimum measured quantity. If the EVSE is designed for the measurement of energy in both directions, then this test shall be applied once with energy flowing in each direction. The effect of an intentional delay in measurement after reversal of the energy direction shall be taken into account when performing the test.

The EVSE shall fulfil the requirements of Table 1.

Mandatory test points: The voltage shall be at reference voltage.

7.3 Tests for influence quantities

7.3.1 General

The purpose of these tests is to verify the requirements of 3.3.4 due to the variation of a single influence quantity. For influence quantities listed in Table 4, it shall be verified that the error shift due to the variation of any single influence quantity is within the corresponding limit of error shift stated in Table 4 (see also the definition of maximum permissible error shift in 2.3.19).

All tests for AC EVSE are performed at the reference voltage unless otherwise stated. All tests for DC EVSE are performed at the highest reference voltage, unless otherwise stated.

7.3.2 Self-heating

Object of the test: To verify that the EVSE is able to carry I_{\max} continuously as specified in Table 4.

Test procedure: AC EVSE: The EVSE shall be run for 6 h at I_{\max} .
DC EVSE: The EVSE shall be run for three charge sessions of 25 kWh each, at a current of I_{\max} with no more than 5 min in between.
Immediately following the above, an accuracy test shall be performed at 50 % I_{\max} . The error shift compared to the intrinsic error shall comply with the requirements given in Table 4 – Maximum permissible error shift due to influence quantities.

7.3.3 Temperature dependence

Object of the test: To verify that the temperature coefficient requirements of Table 3 are fulfilled.

Test procedure: The error of the EVSE shall be determined after reaching temperature stabilisation. The error shall be determined at each of the upper and lower ambient temperature limits specified for the EVSE, and at each of the temperatures from the following list in between:

$$-55\text{ °C}, -40\text{ °C}, -25\text{ °C}, -10\text{ °C}, +5\text{ °C}, \\ +23\text{ °C}, +40\text{ °C}, +55\text{ °C}, +70\text{ °C}, +85\text{ °C}$$

Furthermore, for each pair of test points the temperature coefficient, c , shall be determined as follows:

$$c = \frac{e_u - e_l}{t_u - t_l}$$

where: e_u and e_l are the errors at the upper and the lower temperatures respectively in the temperature interval of interest; and

t_u and t_l are the upper and the lower temperatures respectively in the temperature interval of interest.

Each temperature coefficient shall be in accordance with the requirements of Table 3.

Mandatory test points: The test shall be performed at whichever reference voltage allows the largest current.

The test shall, at minimum, be performed at a current of I_{tr} and 50 % I_{max} .

For AC EVSE a test point is added at I_{max} .

Note: The test can be limited to only the extreme temperatures when the metrology is implemented by a separately approved meter whose type approval specifications meet or exceed those of this Guide.

7.3.4 Voltage variation (AC EVSE)

Object of the test: To verify that the error shift due to voltage variations complies with the requirements of Table 4.

Test procedure: The error shift, compared to the intrinsic error at U_{nom} , shall be measured when the voltage is varied within the corresponding rated operating range. For poly-phase EVSE, the test voltage shall be balanced.

Mandatory test points: If several U_{nom} values are stated, the test shall be run at the $0.9 \times$ the lowest U_{nom} , all U_{nom} , and $1.1 \times$ the highest U_{nom} . The test current shall be 50 % I_{max} .

Acceptance criteria: The error shift shall not exceed that stated in Table 4.

7.3.5 Frequency variation

Object of the test: To verify that the error shift due to frequency variations complies with the requirements of Table 4.

Test procedure: The error shift, compared to the intrinsic error at f_{nom} , shall be measured when the frequency is varied within the corresponding rated operating range. If several f_{nom} values are stated, the test shall be repeated with each f_{nom} value.

Mandatory test points: The test shall, at minimum, be performed at a current of 50 % I_{max} , and at frequencies of $f_{nom} \pm 2$ %.

Acceptance criteria: The error shift shall not exceed that stated in Table 4.

7.3.6 Harmonics in voltage and current

Object of the test: To verify that the error shift due to harmonics for an AC EVSE complies with the requirements of Table 4.

Test procedure: The error shift, compared to the intrinsic error at sinusoidal conditions, shall be measured under each set of conditions described below.

Harmonic amplitudes are calculated relative to the amplitude of the fundamental frequency component of the voltage or current respectively. Phase angle is calculated relative to the zero-crossing of the fundamental frequency voltage or current component respectively.

Mandatory test points: The test shall, at minimum, be performed at 50 % I_{max} .

Test #1: With a sinusoidal reference voltage and current of waveform EV#1 with a fundamental of 50 % I_{max} measure the energy for a delivery of not less than the MMQ.

Acceptance criteria: The error shift shall not exceed that stated in Table 4.

Test #2: With voltage of waveform EV#1 with the fundamental equal to the reference voltage and current of waveform EV#1 with a fundamental of 50 % I_{max} measure the energy for a delivery of not less than the MMQ.

Acceptance criteria: The error shift shall not exceed that stated in Table 4.

Test #3: With voltage waveform EV#2 with the fundamental equal to the reference voltage and current waveform EV#1 with a fundamental of 50 % I_{\max} measure the accuracy for a delivery of not less than the MMQ.

Acceptance criteria: The error shift shall not exceed that stated in Table 4.

Table 12 – EV waveform #1

Harmonic number	Amplitude (%)	Phase angle (°)	Harmonic number	Amplitude (%)	Phase angle (°)
1	100.00	0	2	0.25	188
3	3.00	217	4	0.20	150
5	2.40	212	6	0.16	232
7	2.28	159	8	0.15	205
9	2.16	143	10	0.14	165
11	2.05	254	12	0.00	0.00
13	1.95	95	14	0.00	0.00
15	1.85	188	16	0.00	0.00
17	1.76	266	18	0.00	0.00
19	1.67	168	20	0.00	0.00
21	1.59	216	22	0.00	0.00
23	1.51	247	24	0.00	0.00
25	1.43	240	26	0.00	0.00
27	1.36	120	28	0.00	0.00
29	1.29	239	30	0.00	0.00
31	1.23	29	32	0.00	0.00
33	1.17	133	34	0.00	0.00
35	1.11	59	36	0.00	0.00
37	1.05	135	38	0.00	0.00
39	1.00	370	40	0.00	0.00

Figure 3 – EV waveform #1

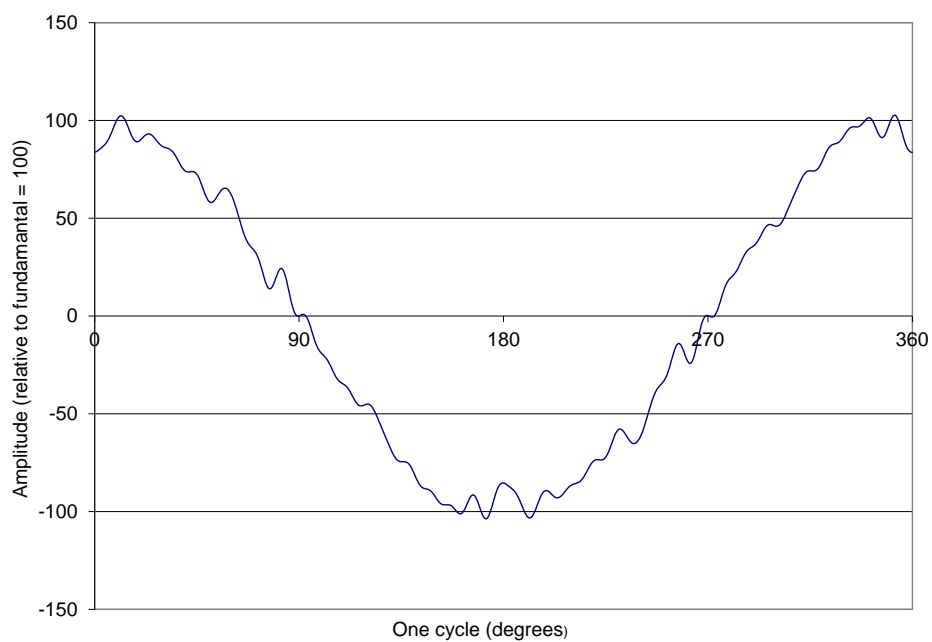
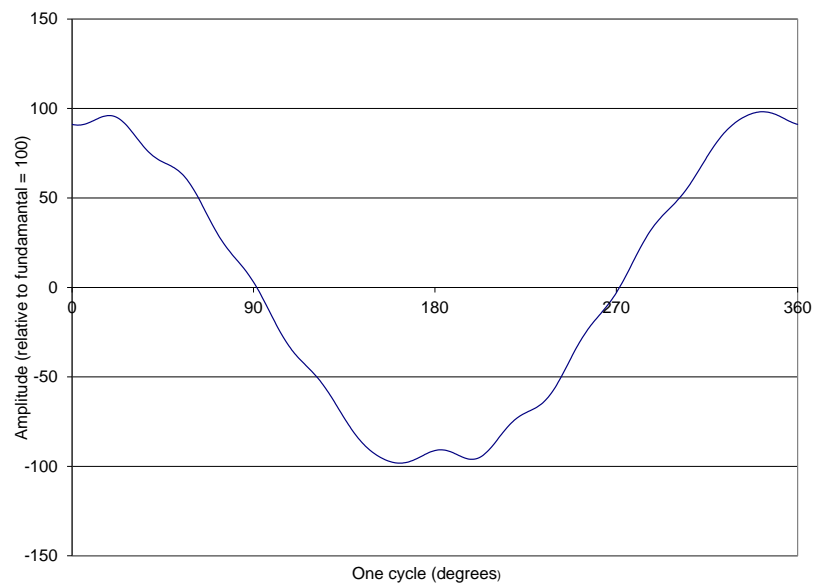

Table 13 – EV waveform #2

Harmonic number	Amplitude (%)	Phase (°)	Harmonic number	Amplitude (%)	Phase (°)
1	100	0	2	0.00	0.00
3	3.80	217	4	0.00	0.00
5	2.40	212	6	0.00	0.00
7	2.28	159	8	0.00	0.00
9	2.16	143	10	0.00	0.00
11	2.05	254	12	0.00	0.00
13	1.70	95	14	0.00	0.00
15	1.85	188	16	0.00	0.00
17	1.76	266	18	0.00	0.00
19	1.67	168	20	0.00	0.00
21	0.00	0.00	22	0.00	0.00
23	0.00	0.00	24	0.00	0.00
25	0.00	0.00	26	0.00	0.00
27	0.00	0.00	28	0.00	0.00
29	0.00	0.00	30	0.00	0.00
31	0.00	0.00	32	0.00	0.00
33	0.00	0.00	34	0.00	0.00
35	0.00	0.00	36	0.00	0.00
37	0.00	0.00	38	0.00	0.00
39	0.00	0.00	40	0.00	0.00

Figure 4 – EV waveform #2



7.3.7 Reversed phase sequence (any two phases interchanged)

Object of the test:	To verify that the error shift due to interchanging any two of the three phases complies with the requirements of Table 4. This test only applies to three-phase EVSE.
Test procedure:	The error shift, compared to the intrinsic error at reference conditions, shall be measured when any two of the three phases are interchanged.
Mandatory test points:	The test shall, at minimum, be performed at a reference current of 50 % I_{\max} with any two of the three phases interchanged. Additional test points may be specified by national authorities.
Acceptance criteria:	The error shift shall not exceed that stated in Table 4.

7.3.8 Continuous (DC) magnetic induction of external origin

Object of the test:	To verify that the error shift due to continuous (DC) magnetic induction of external origin complies with the requirements of Table 4.
Test procedure:	The error shift, compared to the intrinsic error at reference conditions, shall be measured when the EVSE is subjected to continuous magnetic induction with a probe in the form of a permanent magnet with a surface area of at least 2000 mm ² . The magnetic field along the axis of the magnet's core shall comply with details specified in Table 14.
<i>Note:</i>	National authorities may select a lower magnetic induction for national requirements.

Table 14 – Specifications of the field along axis of the magnet's core

Distance from magnet surface	Magnetic induction	Tolerance
30 mm	200 mT	±30 mT

Mandatory test points:	Six points evenly distributed across each EVSE surface, especially at areas where metrologically relevant components are located. The test shall, at minimum, be performed at 50 % I_{\max} . The greatest error shift is to be noted as the test result.
Acceptance criteria:	The error shift shall not exceed that stated in Table 4.
<i>Note:</i>	Neodymium or niobium permanent magnets are recommended for this test.

7.3.9 Magnetic field (AC, power frequency) of external origin

Applicable standard:	IEC 61000-4-8 and where applicable IEC 61851-21-2.
Object of the test:	To verify that the error shift due to an AC magnetic field at power frequency complies with the requirements of Table 4.
Test procedure:	The error shift, compared to the intrinsic error at reference conditions, shall be measured when the EVSE is exposed to a magnetic field at each f_{nom} under the most unfavourable condition of phase and direction.
Test severity:	Continuous field, 400 A/m.
Mandatory test points:	The test shall, at minimum, be performed at 50 % I_{\max} .
Acceptance criteria:	The error shift shall not exceed that stated in Table 4.

7.3.10 Electromagnetic fields

7.3.10.1 Radiated, radio frequency (RF), electromagnetic fields

Applicable standard:	IEC 61000-4-3 and where applicable IEC 61851-21-2.
Object of the test:	To verify that the error shift due to radiated, radio frequency, electromagnetic fields complies with the requirements of Table 4.
Test procedure:	<p>The error shift, compared to the intrinsic error at sinusoidal conditions, shall be measured when the EVSE is subjected to electromagnetic RF fields. The electromagnetic field strength shall be as specified by the severity level and the field uniformity shall be as defined by the standard referenced. The frequency ranges to be considered are swept with the modulated signal, pausing to adjust the RF signal level or to switch oscillators and antennas as necessary. Where the frequency range is swept incrementally, the step size shall not exceed 1 % of the preceding frequency value. The test time for a 1 % frequency change shall not be less than the time to make a measurement and in any case not less than 0.5 s.</p> <p>The cable length exposed to the electromagnetic field shall be 1 m.</p> <p>The test shall be performed with the generating antenna facing each side of the EVSE. When the EVSE can be used in different orientations (i.e., vertical or horizontal) all sides shall be exposed to the fields during the test.</p> <p>The carrier shall be modulated with 80 % AM at 1 kHz sine wave.</p> <p>The EVSE shall be separately tested at the manufacturer's specified clock frequencies.</p> <p>Any other sensitive frequencies shall also be analysed separately.</p> <p><i>Note:</i> Usually these sensitive frequencies can be expected to be the frequencies emitted by the EVSE.</p>
Test condition:	During the test, the EVSE shall be energised with at the lowest U_{nom} and a current equal to 50 % I_{max} . The measurement error of the EVSE shall be monitored by comparison with a reference standard not exposed to the electromagnetic field or immune to the field, or by an equally suitable method. The error at each 1 % incremental interval of the carrier frequency shall be monitored and compared to the requirements of Table 4. When using a continuous frequency sweep, this can be accomplished by adjusting the ratio of the sweep time and the time of each measurement. When using incremental 1 % frequency steps, this can be accomplished by adjusting the dwell time on each frequency to fit the measurement time.
Test severities:	80 MHz to 6000 MHz at a field strength of 10 V/m.
Acceptance criteria:	The error shift shall not exceed that stated in Table 4.

7.3.10.2 Immunity to conducted disturbances, induced by low frequency fields

Applicable standard:	IEC 61000-4-19 and where applicable IEC 61851-21-2.
Object of the test:	To verify an EVSE's immunity against disturbing differential currents in the 2 kHz–150 kHz frequency range originating from power electronics and power line communication systems.
Test procedure:	<p>The test is performed with disturbances in the current only; the test with voltage disturbances is not required. The test shall be carried out according to IEC 61000-4-19:2014, with the following conditions:</p> <p>The differential test current, I_{diff}, shall be applied to the mains port:</p> <ol style="list-style-type: none"> 1) 2 kHz to 30 kHz: $I_{diff} = (2 \pm 0.2) \% I_{max}$, 2) 30 kHz to 150 kHz: $I_{diff} = (0.5 \pm 0.1) \% I_{max}$. <p>The test waves profiles “CW (Continuous Wave) pulses with pause” and “rectangular modulated pulses” shall be used (IEC 61000-4-19:2014, 5.2.2 and 5.2.3).</p> <p>Tests shall be performed at the following frequencies:</p> <p>2 kHz, 3 kHz, 5 kHz, 7 kHz, 10 kHz, 15 kHz, 20 kHz, 30 kHz, 40 kHz, 50 kHz, 70 kHz, 85 kHz, 100 kHz, 120 kHz, 150 kHz</p>
Test conditions:	<p>Voltage set to the lowest U_{nom}</p> <p>Current set to 50 % I_{max}</p>
Acceptance criteria:	The error shift shall not exceed that stated in Table 4.

7.3.10.3 Immunity to conducted disturbances, induced by radiofrequency fields

Applicable standard:	IEC 61000-4-6 and where applicable IEC 61851-21-2
Object of the test:	To verify that the error shift due to conducted disturbances, induced by RF fields complies with the requirements of Table 4.
Test procedure:	<p>A radiofrequency electromagnetic current to simulate the influence of electromagnetic fields shall be coupled or injected into the power ports and I/O ports of the EVSE using coupling/decoupling devices as defined in the standard referenced. The performance of the test equipment consisting of an RF generator, (de)coupling devices, attenuators, etc. shall be verified.</p> <p>The EVSE shall be tested as a table-top instrument. During the test, the EVSE shall be energised with voltage set to the lowest U_{nom} and a current equal to 50 % I_{max}. The error at each 1 % incremental interval of the carrier frequency shall be monitored and compared to the requirements of Table 4. When using a continuous frequency sweep, this can be accomplished by adjusting the ratio of the sweep time and the time of each measurement. When using incremental 1 % frequency steps, this can be accomplished by adjusting the dwell time on each frequency to fit the measurement time. The test time for a 1 % frequency change shall not be less than the time to make a measurement and in any case not less than 0.5 s.</p> <p>If the EVSE is a poly-phase EVSE, the tests shall be performed at all extremities of the cable.</p>
Test severity:	RF amplitude (50 Ω): 10 V (e.m.f.)
Frequency range:	0.15 MHz to 80 MHz

Modulation: 80 % AM, 1 kHz sine wave
 Acceptance criteria: The error shift shall not exceed that stated in Table 4.

7.3.11 Operation of ancillary devices

Object of the test: To verify compliance with the requirements of Table 4 under conditions of operation of ancillary devices. The operation of ancillary devices shall be tested to ensure that they do not affect the metrological performance of the EVSE.

Test procedure: In this test, the EVSE shall be operated at reference conditions and its error continuously monitored, while ancillary devices such as communication devices, relays and other I/O circuits are operated.

Allowed effects: The functionality of the EVSE shall not be impaired and the error shift due to the operation of the ancillary devices shall always be less than the error shift limit specified in Table 4.

Mandatory test point: 50 % I_{max}

Acceptance criteria: The error shift shall not exceed that stated in Table 4.

7.4 Tests for disturbances

7.4.1 General instructions for disturbance tests

These tests are to verify that the EVSE fulfils the requirements for the influence of disturbances as given by Table 5, Table 6 and Table 7. Tests are to be performed using one disturbance at a time; all other influence quantities shall be set to reference conditions unless otherwise stated in the relevant test description. No critical fault shall occur. Unless otherwise stated, each test shall confirm by measurement that the EVSE still fulfils the base maximum permissible error requirements after the disturbance test.

Temporary loss of functionality is allowed as long as the EVSE returns to normal functionality automatically when the disturbance is removed.

For AC EVSE the mandatory test point for the check of base maximum permissible error is 50 % I_{max} , PF = 1.

For DC EVSE the mandatory test point(s) are 50 % I_{max} at between 350 VDC and 400 VDC and for EVSE capable of 800 VDC nominal operation at 50 % I_{max} between 700 VDC and 800 VDC. Ripple shall not exceed the requirements of IEC 61851-23.

7.4.2 Electrostatic discharge

Applicable standard: IEC 61000-4-2 and where applicable IEC 61851-21-2

Object of the test: To verify compliance with the requirements of 3.3.5.2 and Table 5 under conditions of direct and indirect electrostatic discharge.

Test procedure: An ESD generator shall be used with performance characteristics specified in the referenced standard. Before starting the tests, the performance of the generator shall be verified. At least 10 discharges, in the most sensitive polarity, shall be applied. For an EVSE not equipped with a ground terminal, the EVSE shall be fully discharged between discharges. Contact discharge is the preferred test method. Air discharges shall be used where contact discharge cannot be applied.

Direct application: In the contact discharge mode to be carried out on conductive surfaces, the electrode shall be in contact with the EVSE. In the air discharge mode on

insulated surfaces, the electrode is approached to the EVSE and the discharge occurs by spark.

Indirect application: The discharges are applied in the contact mode to coupling planes mounted in the vicinity of the EVSE.

Test #1: A transaction shall be performed at U_{nom} and 50 % I_{max} for a sufficient quantity of energy to allow all of the discharges to be applied.
Apply the discharges during the transaction.

Allowed effects: No critical fault shall occur. If the transaction is interrupted by the discharges, it shall be terminated without billing of the customer unless the EVSE can determine with certainty that the transaction data remains valid.

Test #2: After Test #1 is completed, a transaction shall be performed at U_{nom} and 50 % I_{max} for a delivery of at least the MMQ of energy.

Allowed effects: An error shift larger than 1.0 BMPE constitutes shall not occur.

Test severity: Contact discharge voltage (1): 6 kV
Air discharge voltage (2): 8 kV
Note 1: Contact discharges shall be applied on conductive surfaces.
Note 2: Air discharges shall be applied on non-conductive surfaces.

Performance verification: Accuracy test.

Mandatory test points: 50 % I_{max}

Allowed effects: No damage shall occur. Error shift less than 1.0 BMPE.

7.4.3 Fast transients

Applicable standards: IEC 61000-4-1, IEC 61000-4-4 and where applicable IEC 61851-21-2.

Object of the test: To verify compliance with the requirements of 3.3.5.2 and Table 5 under conditions where electrical bursts are superimposed on voltage and current circuits, and I/O and communication ports.

Test procedure: A burst generator shall be used with the performance characteristics specified in the referenced standard. The EVSE shall be subjected to bursts of voltage spikes for which the repetition frequency of the impulses and peak values of the output voltage on 50 Ω and 1000 Ω loads are defined in the referenced standard. The characteristics of the generator shall be verified before connecting the EVSE. Both positive and negative polarity bursts shall be applied. The duration of the test shall not be less than 1 min for each amplitude and polarity. A capacitive coupling clamp, as defined in the standard, shall be used to couple to I/O and communication lines with a reference voltage over 40 V. The test pulses shall be applied continuously during the measurement time.

Test conditions: The EVSE voltage and auxiliary circuits shall be energised with reference voltage.
The cable length between the coupling device and the EVSE shall be 1 m.
The test voltage shall be applied in common mode (line-to-earth) to:

- the input power circuits;

- the auxiliary circuits, if separated from the voltage circuits in normal operation and with a reference voltage over 40 V.

Test severity: Test voltage on the input power circuits: 2 kV.
Test voltage on auxiliary circuits with a reference voltage over 40 V: 1 kV.

Performance verification: Accuracy test.

Mandatory test points: 50 % I_{\max}

Allowed effects: No damage shall occur. Error shift less than 1.0 BMPE.

7.4.4 Voltage dips and interruptions

Applicable standards: IEC 61000-4-11, IEC 61000-4-34.

Object of the test: To verify compliance with the requirements of 3.3.5.2 and Table 5 under conditions of short time mains voltage reductions (dips and interruptions).

Test procedure: A test generator, which is able to reduce the amplitude of the AC mains voltage over an operator-defined period of time, shall be used in this test. The performance of the test generator shall be verified before connecting the EVSE.

The mains voltage reductions shall be repeated 10 times with an interval of at least 10 s.

Test conditions: Perform during a transaction with voltage circuits initially energised with U_{nom} and no current flowing. If the EVSE shuts down at any point during either test that test is considered complete.

Test severities: Voltage dips:

Test	Test a	Test b	Test c
Reduction:	to 30 % U_{nom}	to 60 % U_{nom}	to 60 % U_{nom}
Duration:	0.5 cycles	1 cycle	25 cycles (50 Hz) 30 cycles (60 Hz)

Voltage interruption test:

Reduction:	to 0 % U_{nom}
Duration:	250 cycles (50 Hz) 300 cycles (60 Hz)

Allowed effect: The transaction shall terminate when the EVSE shuts down, or the transaction shall be cancelled, unless it can be completed once power is restored with certainty that the transaction data is correct.

Performance verification: Accuracy test.

Mandatory test points: 50 % I_{\max}

Allowed effects: Error shift less than 1.0 BMPE.

7.4.5 Surges on AC mains power lines

Applicable standard:	IEC 61000-4-5 and where applicable IEC 61851-21-2
Object of the test:	To verify compliance with the requirements of 3.3.5.2 and Table 5 under conditions where electrical surges are superimposed on the mains voltage and, if applicable, on I/O and communication ports.
Test procedure:	<p>A surge generator shall be used with the performance characteristics specified in the referenced standard. The test consists of exposure to surges for which the rise time, pulse width, peak values of the output voltage/current on high/low impedance load, and minimum time interval between two successive pulses are defined in the referenced standard.</p> <p>The characteristics of the generator shall be verified before connecting the EVSE.</p>
Test conditions:	<p>The EVSE shall be in operating condition:</p> <ul style="list-style-type: none">▪ voltage circuits energised with highest U_{nom};▪ current circuit connected as provided in IEC 61851-21-2;▪ cable length between surge generator and EVSE: 1 m;▪ tested in differential mode (line to line);▪ phase angle: pulses to be applied at 60° and 240° relative to zero crossing of AC supply.
Test severities:	<p>Voltage circuits:</p> <ul style="list-style-type: none">▪ Line to line: Test voltage: 2.0 kV, generator source impedance: 2Ω;▪ Line to earth⁽¹⁾: Test voltage: 4.0 kV, generator source impedance: 2Ω;▪ Number of tests: five positive and five negative;▪ Repetition rate: maximum 1/min. <p>Auxiliary circuits with a reference voltage over 40 V:</p> <ul style="list-style-type: none">▪ Line to line: Test voltage 1.0 kV, generator source impedance 42Ω;▪ Line to earth⁽¹⁾: Test voltage 2.0 kV, generator source impedance 42Ω;▪ Number of tests: five positive and five negative;▪ Repetition rate: maximum 1/min. <p><i>Note</i>⁽¹⁾: For cases where the earth of the EVSE is separate to neutral.</p>
Performance verification:	Accuracy test.
Mandatory test points:	50 % I_{max}
Allowed effects:	No critical fault. No damage shall occur. Error shift less than 1.0 BMPE.

7.4.6 Short-time overcurrent

Object of the test:	To verify compliance with the requirements of 3.3.5.2 and Table 5 under conditions of a short time overcurrent.
Test procedure:	The EVSE shall be able to handle the current caused by a short-circuit within the electric vehicle.

Note: National authorities may specify specific fuses or breakers to be applied.

Test current:	A current equivalent to $5 \times I_{\max}$ (+0 %, –10 %) limited to a maximum of 3 kA, for 0.5 cycle. The test current shall be applied to one phase at the time. The test current value given is the RMS value, not the peak value.
Allowed effects:	No damage shall occur.
Performance verification:	Accuracy test.
Mandatory test points:	50 % I_{\max} .
Allowed effects:	No critical fault. No damage shall occur. Error shift less than 1.0 BMPE.

7.4.7 Impulse voltage

7.4.7.1 General

Applicable standards:	IEC 60664-1 and where applicable IEC 61851-21-2.												
Object of the test:	To verify compliance with the requirements of 3.3.5.2 and Table 5 under conditions of impulse voltage.												
Test procedure:	<p>The EVSE and its incorporated ancillary devices, if any, shall be such that they retain adequate dielectric qualities, taking account of the atmospheric influences and different voltages to which they are subjected under normal conditions of use.</p> <p>The EVSE shall withstand the impulse voltage tests specified in 7.4.7.2 and 7.4.7.3. The test shall be carried out only on complete EVSE.</p> <p>For each test (see 7.4.7.2 and 7.4.7.3) the impulse voltage is applied five times with one polarity and then repeated five times with the other polarity. The minimum time between impulses shall be 5 s.</p> <p>For the purpose of these tests, the term “earth” has the following meaning:</p> <ul style="list-style-type: none"> ▪ when the EVSE case is made of metal, the “earth” is the case itself, placed on a flat, conducting surface; ▪ when the EVSE case or only part of it is made of insulating material, the “earth” is a conductive foil wrapped around the EVSE touching all accessible conductive parts and connected to the flat, conducting surface on which the EVSE is placed. The distances between the conductive foil and the terminals, and between the conductive foil and the holes for the conductors, shall be no more than 2 cm. <p>During the impulse voltage test, the circuits that are not under test shall be connected to the earth.</p>												
Test conditions:	<table> <tr> <td>ambient temperature:</td> <td>15 °C to 25 °C;</td> </tr> <tr> <td>relative humidity:</td> <td>25 % to 75 %;</td> </tr> <tr> <td>atmospheric pressure:</td> <td>86 kPa to 106 kPa;</td> </tr> <tr> <td>impulse waveform:</td> <td>1.2/50 µs impulse specified in IEC 60060-1;</td> </tr> <tr> <td>voltage rise time:</td> <td>±30 %;</td> </tr> <tr> <td>voltage fall time:</td> <td>±20 %;</td> </tr> </table>	ambient temperature:	15 °C to 25 °C;	relative humidity:	25 % to 75 %;	atmospheric pressure:	86 kPa to 106 kPa;	impulse waveform:	1.2/50 µs impulse specified in IEC 60060-1;	voltage rise time:	±30 %;	voltage fall time:	±20 %;
ambient temperature:	15 °C to 25 °C;												
relative humidity:	25 % to 75 %;												
atmospheric pressure:	86 kPa to 106 kPa;												
impulse waveform:	1.2/50 µs impulse specified in IEC 60060-1;												
voltage rise time:	±30 %;												
voltage fall time:	±20 %;												

source energy: $(10.0 \pm 1.0) \text{ J}$;
 test voltage: in accordance with Table 15;
 test voltage tolerance: $+0 -10 \%$.

Note: The selection of the source impedance is at the discretion of the testing laboratory.

Performance verification: Accuracy test.

Mandatory test points: $50 \% I_{\max}$

Allowed effects: No critical fault. No damage shall occur. Error shift less than 1.0 BMPE.

Table 15 – Impulse voltage test levels

EVSE type	Rated voltage, U	Applied impulse voltage (kV)
AC	$100 \text{ V} \leq U < 150 \text{ V}$	1.5
	$150 \text{ V} \leq U < 300 \text{ V}$	2.5
	$300 \text{ V} \leq U < 600 \text{ V}$	4.0
	$U \geq 600 \text{ V}$	4.0
<i>Note:</i> Impulse voltage levels are set in accordance with IEC 60664-1:2020 Table F.1. overvoltage category II. National authorities may change the applicable rated impulse voltage levels.		

7.4.7.2 Impulse voltage tests for circuits and between circuits

Test procedure: The test shall be made independently on each circuit (or assembly of circuits) which is insulated from other circuits of the EVSE in normal use. The terminals of the circuits which are not subjected to impulse voltage shall be connected to earth.

Thus, when the voltage and current circuits of a measuring element are connected together in normal use, the test shall be made on the whole EVSE. The other end of the voltage circuit shall be connected to earth and the impulse voltage shall be applied between the terminal of the current circuit and earth. When several voltage circuits of a EVSE have a common point, this point shall be connected to earth and the impulse voltage successively applied between each of the free ends of the connections (or the current circuit connected to it) and earth. The other end of this current circuit shall be open.

When the voltage and current circuits of the same measuring element are separated and appropriately insulated in normal use (e.g. each circuit is connected to a measuring transformer), the test shall be made separately on each circuit.

During the test of a current circuit, the terminals of the other circuits shall be connected to earth and the impulse voltage shall be applied between one of the terminals of the current circuit and earth. During the test of a voltage circuit, the terminals of the other circuits and one of the terminals of the voltage circuit under test shall be connected to earth and the impulse voltage shall be applied between the other terminal of the voltage circuit and earth.

The auxiliary circuits intended to be connected either directly to the mains or to the same voltage transformers as the EVSE circuits, and with a reference voltage over 40 V, shall be subjected to the impulse voltage test by being tied together with a voltage circuit during tests. The other auxiliary circuits shall not be tested.

Performance verification: Accuracy test.

Mandatory test points: 50 % I_{max} .

Allowed effects: No critical fault. No damage shall occur. Error shift less than 1.0 BMPE.

7.4.7.3 Impulse voltage test of electric circuits relative to earth

Test procedure: All the terminals of the electric circuits of the EVSE, including those of the auxiliary circuits with a reference voltage over 40 V, shall be connected together.

The auxiliary circuits with a reference voltage below or equal to 40 V shall be connected to earth. The impulse voltage shall be applied between all the electric circuits and earth.

Performance verification: Accuracy test.

Mandatory test points: 50 % I_{max}

Allowed effects: No critical fault. No damage shall occur. Error shift less than 1.0 BMPE. No flashover, disruptive discharge or puncture shall occur.

7.4.8 Environmental tests

Tests 7.4.8.1–7.4.8.7 comprise a suite of tests for immunity to various environmental disturbances. All tests are performed with the EVSE unpowered. Tests may be performed in any order. All tests in 7.4.8 may be performed as a group with a single accuracy test before and after the group of tests.

7.4.8.1 Protection against solar radiation

Applicable standard: ISO 4892-3.

Object of the test: To verify compliance with the requirements of Table 6 regarding protection against solar radiation. For outdoor EVSE exposed to direct sunlight only.

Test apparatus: Lamp type/wavelength: UVA 340;

Black panel thermometer;

Light meter;

Cycling rig with a condensation cycle to comply with the parameters in the test conditions.

Test conditions: The EVSE shall be in non-operating condition.

Test cycle (12 h cycle)	Lamp type	Spectral irradiance	Black panel temperature
8 h dry	UVA 340	0.76 W/m ² /nm at 340 nm	(60 ± 3) °C
4 h condensation		Light off	(50 ± 3) °C

Test procedure: Partially mask a section of the EVSE for later comparison. Expose the EVSE to artificial radiation and weathering in accordance with ISO 4892-3 for a

period of 66 days (132 cycles) and in accordance with the test conditions above.

Allowed effects: After the test the EVSE shall be visually inspected and a functional test shall be performed. The appearance and, in particular, the legibility of markings and displays shall not be altered. Any means of protection of the metrological properties, such as the case and sealing, shall not be affected. The function of the EVSE shall not be impaired.

7.4.8.2 Protection against ingress of dust

Applicable standards: IEC 60529, IEC 61851-1.

Object of the test: To verify compliance with the requirements of 3.3.5.3 and Table 6 regarding protection against the ingress of dust.

Test conditions: Reference conditions;
IP 5X rating;
Category 2 enclosure.

Test procedure: After the test the interior of the EVSE shall be visually inspected and a functional test shall be performed.

Allowed effects: The talcum powder or other dust used in the test shall not have accumulated in a quantity or location such that it could interfere with the correct operation of the equipment or impair safety. No dust shall deposit where it could lead to tracking along the creepage distances. The function of the EVSE shall not be impaired.

7.4.8.3 Extreme temperatures - dry heat

Applicable standards: IEC 60068-2-2, IEC 60068-3-1.

Object of the test: To verify compliance with the requirements of 3.3.5.3 and Table 6 under conditions of dry heat.

Test procedure: The test consists of exposure to the specified high temperature under “free air” conditions for 2 h (beginning from when the temperature of the EVSE is stable), with the EVSE in a non-operating state.

The change of temperature shall not exceed 1 °C/min during heating up and cooling down.

The absolute humidity of the test atmosphere shall not exceed 20 g/m³.

Test severity: The test shall be performed at a standard temperature one step higher than the upper temperature limit specified for the EVSE.

Possible temperatures: 40 °C, 55 °C, 70 °C, 85 °C.

Allowed effects: After the test, the function of the EVSE shall not be impaired and the error shift shall not exceed the limit of error shift listed in Table 6.

Mandatory test points: 50 % I_{max}

7.4.8.4 Extreme temperatures - cold

Applicable standards: IEC 60068-2-1, IEC 60068-3-1.

Object of the test: To verify compliance with the requirements of 3.3.5.3 and Table 6 under conditions of low temperatures.

Test procedure:	The test consists of exposure to the specified low temperature under “free air” conditions for 2 h (beginning from the time when the temperature of the EVSE is stable) with the EVSE in a non-operating state. The change of temperature shall not exceed 1 °C/min during heating up and cooling down.
Test severity:	The test shall be performed at a standard temperature one step lower than the lower temperature limit specified for the EVSE.
Possible temperatures:	–10 °C, –25 °C, –40 °C, –55 °C ⁽¹⁾ .
Allowed effects:	After the test, the function of the EVSE shall not be impaired and the error shift shall not exceed the limit of error shift listed in Table 6.
Mandatory test points:	50 % I_{max} ^{(1)Note:} If the specified lower temperature limit is –55 °C, then this test shall be performed at –55 °C.

7.4.8.5 Damp heat, steady-state (non-condensing), for humidity class H1

Applicable standards:	IEC 60068-2-78, IEC 60068-3-4.
Object of the test:	To verify compliance with the requirements of 3.3.5.3 and Table 6 under conditions of high humidity and constant temperature. This test applies to EVSE that are specified for enclosed locations where the EVSE are not subjected to condensed water, precipitation, or ice formations (H1).
Test procedure:	The test consists of exposure to the specified high-level temperature and the specified constant relative humidity for a certain fixed time defined by the severity level. The EVSE shall be handled such that no condensation of water occurs on it.
Test conditions:	Voltage and auxiliary circuits energised with reference voltage; Without any current in the current circuits.
Test severity:	Temperature: 30 °C; Humidity: 85 %; Duration: 2 days.
Allowed effects:	During the test no critical fault shall occur. Immediately after the test the EVSE shall operate correctly and comply with the accuracy requirements of Table 6. 24 h after the test the EVSE shall be submitted to a functional test during which it shall be demonstrated to operate correctly. There shall be no evidence of any mechanical damage or corrosion which may affect the functional properties of the EVSE.

7.4.8.6 Damp heat, cyclic (condensing) for humidity classes H2 and H3

Applicable standards:	IEC 60068-2-30, IEC 60068-3-4.
Object of the test:	To verify compliance with the requirements in 3.3.5.3 and Table 6 under conditions of high humidity and temperature variations. This test applies to EVSE with a humidity class specification either for enclosed locations where EVSE can be subjected to condensed water or for open locations (humidity classes H2 and H3).

Test procedure: The test consists of exposure to cyclic temperature variation between 25 °C and the temperature specified as the upper temperature according to the test severities below, whilst maintaining the relative humidity above 95 % during the temperature change and low temperature phases, and at 93 % during the upper temperature phases. Condensation should occur on the EVSE during the temperature rise.

The 24 h cycle consists of:

- a) temperature rise during 3 h;
- b) temperature maintained at upper value until 12 h from the start of the cycle;
- c) temperature reduced to lower value within 3 h to 6 h, the rate of fall during the first hour and a half being such that the lower value would be reached in 3 h;
- d) temperature maintained at lower value until the 24 h cycle is completed.

The stabilising period before and recovery after the cyclic exposure shall be such that all parts of the EVSE are within 3 °C of their final temperature.

Test conditions: Voltage and auxiliary circuits energised with reference voltage;

Without any current in the current circuits;

Mounting position according to manufacturer's specification.

Test severities: EVSE with a humidity class specification for enclosed locations where EVSE can be subjected to condensed water shall be tested at severity level 1. EVSE with a humidity class specification for open locations shall be tested at severity level 2.

Specified humidity class:	H2	H3
Severity levels:	1	2
Upper temperature (°C):	40	55
Duration (cycles):	2	2

Allowed effects: During the test no critical fault shall occur.

Immediately after the test the EVSE shall operate correctly and comply with the accuracy requirements of Table 4.

24 h after the test, the EVSE shall be submitted to a functional test during which it shall be demonstrated to operate correctly. There shall be no evidence of any mechanical damage or corrosion which may affect the functional properties of the EVSE.

7.4.8.7 Water test

Applicable standards: IEC 60068-2-18, IEC 60512-14-7, IEC 60529.

Object of the test: To verify compliance with the requirements in 3.3.5.3 and Table 6 under conditions of rain and water splashes. The test is applicable to EVSE that are specified for open locations (H3).

Test procedure:	The EVSE is mounted on an appropriate fixture and is subjected to impacting water generated from either an oscillating tube or a spray nozzle used to simulate spraying or splashing water.
Test conditions:	The EVSE shall be in functional mode during the test; Flow rate (per nozzle): 0.07 L/min.
Duration:	10 min.
Angle of inclination:	0 ° and 180 °.
Allowed effects:	During the test no critical fault shall occur. Immediately after the test the EVSE shall operate correctly and comply with the accuracy requirements of Table 6. 24 h after the test the EVSE shall be submitted to a functional test during which it shall be demonstrated to operate correctly and comply with the accuracy requirements of Table 2. There shall be no evidence of any mechanical damage or corrosion which may affect the functional properties of the EVSE.

7.4.9 Durability test

Object of the test:	To verify compliance with the requirements of 3.4 for durability.
Test procedure:	The test procedure for durability shall subject a number of EVSE to the conditions below. The EVSE accuracy shall be determined prior to and after the durability test.
Test conditions:	A minimum of 1 EVSE.
Test temperature:	Maximum operating temperature specified by the manufacturer.
Test voltage:	Reference voltage.
Test load:	50 % I_{max} .
Test sequence:	Application of the load during 8 h, followed by 16 h without any current.
Test duration:	10 cycles.
Mandatory test points:	For initial and final measurement, the voltage shall be the reference voltage, with the following test points: I_{tr} and 50 % I_{max} <i>Note:</i> As indicated in clause 6 the test is allowed to be performed with either real power or phantom power.

7.4.10 Mechanical tests

All tests in 7.4.10 may be performed as a group with a single accuracy test before and after the group of tests.

Note: National authorities may eliminate any of these tests when the EVSE is too large to perform the test reasonably and at a reasonable cost.

If these tests are eliminated from type approval, initial verification testing shall be performed after installation of the EVSE and prior to the EVSE being put into service.

7.4.10.1 Vibrations

Applicable standards: IEC 60068-2-47, IEC 60068-2-64.

Object of the test: To verify compliance with the requirements of 3.3.6 and Table 7 under conditions of vibrations.

Test procedure: The EVSE shall, in turn, be tested in three, mutually perpendicular axes whilst mounted on a rigid fixture by its normal mounting means.

The EVSE shall normally be mounted so that the gravitational force acts in the same direction as it would in normal use. Where the effect of gravitational force is not important the EVSE may be mounted in any position.

Test severity:

Total frequency range	10 Hz to 150 Hz
Total RMS level	7 m s ⁻²
Acceleration Spectral Density (ASD) level 10–20 Hz	1 m ² s ⁻³
Acceleration Spectral Density (ASD) level 20–150 Hz	–3 dB/octave
Duration per axis:	at least 2 min

Mandatory test points: 50 % I_{\max}

Allowed effects: After the test, the function of the EVSE shall not be impaired and the error shift, at 50 % I_{\max} , shall not exceed 1.0 BMPE.

7.4.10.2 Shock

Applicable standard: IEC 60068-2-27.

Object of the test: To verify compliance with the requirements of 3.3.6 and Table 7 under conditions of shock.

Test procedure: The EVSE is subjected to non-repetitive shocks of standard pulse shapes with specified peak acceleration and duration. During the test, the EVSE shall not be operational and it shall be fastened to a fixture or to the shock-testing machine.

Test severity: Pulse shape: Half-sine

Peak acceleration: 30 g_n

Pulse duration: 18 ms

Allowed effects: No critical fault. Function of the EVSE shall not be impaired.

Performance verification: Accuracy test.

Mandatory test points: 50 % I_{\max}

Allowed effects: After the test, the function of the EVSE shall not be impaired and the error shift, at 50 % I_{\max} , shall not exceed 1.0 BMPE.

8 Examination for conformity with type

An examination for conformity to type should determine whether a EVSE complies with all the requirements in 3, and whether documentation supplied by the manufacturer complies with the requirements in 5.1.

An EVSE may only be deemed to have passed examination for conformity to type if the results of all the type tests comply with the requirements in 3. The measurement uncertainty must be small enough to allow clear discrimination between a pass result and a fail result. In particular, an uncertainty less than one fifth of the maximum permissible error given for the corresponding test point must be obtained for tests described in 7.2, unless otherwise specified in the relevant test description.

The scope of the tests performed and the test severities used shall be consistent with the manufacturer's specifications and with the requirements of 3.

9 Verification and re-verification

9.1 General

Verification may be carried out either individually or statistically. In all cases EVSE shall conform to the requirements of this Guide. As noted in 3.3.3, national authorities may specify the base maximum permissible errors for subsequent verification and re-verification. The following minimum programme applies to the initial verification of all EVSE, whether verified individually or statistically, and to re-verification of EVSE which have been repaired or otherwise changed. For individual or statistical re-verification of EVSE that have not been repaired or otherwise changed, the programme may be modified and further reduced.

The exact requirements for verification and re-verification shall be specified by the national authority.

9.2 Testing

9.2.1 Calibration status

Check that the test system used has sufficient accuracy to verify the EVSE under test, and that the calibration is valid.

9.2.2 Conformity check

Check that the instrument is manufactured in conformity with the type approval documentation.

9.2.3 Warming-up

It may be necessary to warm up the EVSE up before full operation. The length of the warm-up period depends on the actual type of EVSE and shall be determined in advance. The order of the test points shall be from lowest current to highest current and then from highest current to lowest current. For each test point, the resulting error shall be the mean of these measurements.

9.2.4 Minimum test programme

The minimum programme consists of:

- starting current check;
- current dependence.

9.2.4.1 Starting current check

The test is performed at I_{st} .

The requirement is that the EVSE register at least 75 % of the energy delivered (refer to the test procedure in 7.2.2).

If an AC EVSE can operate in both single-phase and three-phase modes, then both modes shall be tested.

9.2.4.2 Current dependence

EVSE shall comply with the accuracy requirements of Table 2. As a minimum these shall be checked at the following currents:

$$I_{\min}, \quad I_{\text{tr}}, \quad 50 \% I_{\max}, \quad I_{\max}$$

If an EVSE can operate in both single-phase and three-phase modes, then both modes shall be tested.

For EVSE operating at a voltage in the range 208 V–240 V, testing may be done at any U_{nom} within the range. Otherwise, tests shall be run at the lowest U_{nom} and the highest U_{nom} .

9.2.5 Sealing

If there are no seals on the EVSE (e.g. because they have not yet been applied or because they have been removed during verification testing), the EVSE shall be sealed in accordance with the requirements specified by national authorities.

9.3 Reference conditions for initial and subsequent verifications in a laboratory

Reference conditions and load conditions for initial and subsequent verifications in a laboratory are given in Table 16 and Table 17. National authorities may specify tighter tolerances.

Table 16 – Reference conditions and their tolerances for initial and subsequent verification

Quantity	Reference conditions AC	Reference conditions DC
Voltage(s)	U_{nom} of the (intended) installation $\pm 2\%$	(375 \pm 50) VDC, (750 \pm 50) VDC
Current	50 % I_{max}	50 % I_{max}
Ambient temperature	23 °C \pm 5 °C	23 °C \pm 5 °C
Frequency	f_{nom}	DC as generated by EVSE
Waveform	Sinusoidal $d \leq 2\%$	DC as generated by EVSE
Magnetic induction of external origin at reference frequency	0 T $\leq B \leq$ 0.1 mT	0 T $\leq B \leq$ 0.1 mT
Electromagnetic RF fields 30 kHz – 6 GHz	< 2 V/m	< 2 V/m
Phase sequence for poly-phase EVSE	L1, L2, L3	N/A
Load balance	Equal current in all current circuits $\pm 5\%$ and $\pm 5^\circ$	N/A

Table 17 – Load conditions and their tolerances in tests for initial and subsequent verification

Current(s)	Current range of device under test	Class A, B: $\pm 10\%$ Class C: $\pm 10\%$
Power factor	Power factor range of device under test	Current to voltage phase difference $\pm 5^\circ$

9.4 Additional requirements for statistical verifications

This section contains additional requirements for verification on a statistical basis.

Note: National authorities shall determine whether the use of statistical methods is permitted.

9.4.1 Lot

A lot shall consist of EVSE with homogeneous characteristics. All the EVSE that comprise the lot shall correspond to the same type approval, and shall have the same year of manufacture.

9.4.2 Samples

Samples shall be randomly taken from a lot.

9.4.3 Statistical testing

The statistical control shall be based on attributes. The sampling system shall ensure:

- An Acceptance Quality Level (AQL) of not more than 1 %; and
- A Limiting Quality (LQ) of not more than 7 %.

The AQL is the maximum percentage of non-conforming items in a lot at which the lot has a probability of 95 % to be accepted.

The LQ is the percentage of non-conforming items in a lot at which the lot has a maximum probability of 5 % to be accepted.

Note: These requirements allow for substantial freedom in the verification program. Examples are given below based on a lot of 1000 EVSE.

Number of EVSE tested	40	70	100	1000
Maximum number of non-conforming EVSE	0	1	2	10

9.5 Field testing

Field testing may be used for either verification or re-verification if allowed by the national authority, which may set lower accuracy requirements for field testing based on the lack of control over the environment's conditions of the tests.

Annex A

Bibliography

(Informative)

Ref.	Standards and reference documents	Description
[1]	OIML D 11:2013 <i>General requirements for electronic measuring instruments</i>	Guidance for establishing appropriate metrological performance testing requirements for influence quantities that may affect the measuring instruments covered by OIML Recommendations.
[2]	OIML D 31:2019 <i>General requirements for software controlled measuring instruments</i>	Guidance for establishing appropriate requirements for software related functionalities in measuring instruments covered by OIML Recommendations.
[3]	OIML V 2-200:2012 <i>International Vocabulary of Metrology – Basic and General Concepts and Associated Terms (VIM)</i>	Vocabulary, prepared by a joint working group consisting of experts appointed by BIPM, IEC, IFCC, ISO, IUPAC, IUPAP, and OIML.
[4]	OIML V 1:2013 <i>International vocabulary of terms in legal metrology (VIML)</i>	The VIML includes only the concepts used in the field of legal metrology. These concepts concern the activities of the legal metrology service, the relevant documents, as well as other problems linked with this activity. Also included in this Vocabulary are certain concepts of a general character which have been drawn from the VIM.
[5]	OIML G 1-100:2008 <i>Evaluation of measurement data - Guide to the expression of uncertainty in measurement (GUM)</i>	This Guide establishes general rules for evaluating and expressing uncertainty in measurement that are intended to be applicable to a broad spectrum of measurements.
[6]	OIML G 20:2017 <i>Surveillance of utility meters in service on the basis of sampling inspections</i>	This Guide relates to the method and procedure according to which the period of validity of the verification of utility meters forming part of a defined lot is extended if the correctness of the meters has been proved by sampling inspections prior to the expiry of the period of validity of the verification.
[7]	IEC 60060-1:2010 High-voltage test techniques - Part 1: General definitions and test requirements	This part of IEC 60060 is applicable to: <ul style="list-style-type: none"> – dielectric tests with direct voltage; – dielectric tests with alternating voltage; – dielectric tests with impulse voltage; – dielectric tests with combinations of the above.

Ref.	Standards and reference documents	Description
[8]	IEC 60068-2-1:2007 Environmental testing - Part 2-1: Tests - Test A: Cold	This part of IEC 60068 deals with cold tests applicable to both non heat-dissipating and heat-dissipating specimens. The object of the cold test is limited to the determination of the ability of components, equipment or other articles to be used, transported or stored at low temperature. Cold tests covered by this Standard do not enable the ability of specimens to withstand or operate during the temperature variations to be assessed. In this case, it would be necessary to use IEC 60068-2-14.
[9]	IEC 60068-2-2:2007 Environmental testing - Part 2-2: Tests. Test B: Dry heat	This part of IEC 60068 deals with dry heat tests applicable both to heat-dissipating and non heat-dissipating specimens. The object of the dry heat test is limited to the determination of the ability of components, equipment or other articles to be used, transported or stored at high temperature. These dry heat tests do not enable the ability of specimens to withstand or operate during the temperature variations to be assessed. In this case, it would be necessary to use IEC 60068-2-14 Test N: Change of temperature.
[10]	IEC 60068-2-18:2017 Environmental testing - Part 2-1: Test R and guidance: Water	Provides methods of test applicable to products which, during transportation, storage or in service, may be subjected to falling drops, impacting water or immersion. The primary purpose of water tests is to verify the ability of enclosures, covers and seals to maintain components and equipment in good working order after and, when necessary, under a standardized dropfield or immersion in water.
[11]	IEC 60068-2-27:2008 Environmental testing - Part 2-27: Tests - Test Ea and guidance: Shock	Provides a standard procedure for determining the ability of a specimen to withstand specified severities of non-repetitive or repetitive shocks. The purpose of this test is to reveal mechanical weakness and/or degradation in specified performances, or accumulated damage or degradation caused by shocks.
[12]	IEC 60068-2-30:2005 Environmental testing - Part 2-30: Tests - Test Db: Damp heat, cyclic (12 h + 12 h cycle)	Determines the suitability of components, equipment and other articles for use and/or storage under conditions of high humidity when combined with cyclic temperature changes.
[13]	IEC 60068-2-47:2005 Environmental testing - Part 2-47: Test - Mounting of specimens for vibration, impact and similar dynamic tests	Provides methods of mounting components, and mounting requirements for equipment and other articles, for the families of dynamic tests in IEC 60068-2, that is impact (Test E), vibration (Test F) and acceleration, steady-state (Test G).

Ref.	Standards and reference documents	Description
[14]	IEC 60068-2-64:2008 Environmental testing - Part 2-64: Test methods - Test Fh: Vibration, broad-band random (digital control) and guidance	Determines the ability to withstand specified severities of broad-band random vibration. Applies to specimens which may be subjected to vibration of a stochastic nature by transportation or operational environments, for example in aircraft, space vehicles and land vehicles. Has the status of a basic safety publication in accordance with IEC Guide 104.
[15]	IEC 60068-2-78:2012 Environmental testing - Part 2-78: Tests - Test Cab: Damp heat, steady state	Provides a test method for determining the suitability of electrotechnical products, components or equipment for transportation, storage and use under conditions of high humidity. The test is primarily intended to permit the observation of the effect of high humidity at constant temperature without condensation on the specimen over a prescribed period.
[16]	IEC 60068-3-1:2011 Environmental testing - Part 3-1: Supporting documentation and guidance - Cold and dry heat tests	Gives background information for Tests A: Cold (IEC 68-2-1), and Tests B: Dry heat (IEC 68-2-2). Includes appendices on the effect of: chamber size on the surface temperature of a specimen when no forced air circulation is used; airflow on chamber conditions; on surface temperatures of test specimens; wire termination dimensions and material on surface temperature of a component; measurements of temperature, air velocity and emission coefficient.
[17]	IEC 60068-3-4:2001 Environmental testing - Part 3-4: Supporting documentation and guidance - Damp heat tests	Provides the necessary information to assist in preparing relevant specifications, such as standards for components or equipment, in order to select appropriate tests and test severities for specific products and, in some cases, specific types of application. The object of damp heat tests is to determine the ability of products to withstand the stresses occurring in a high relative humidity environment, with or without condensation, and with special regard to variations of electrical and mechanical characteristics. Damp heat tests may also be utilized to check the resistance of a specimen to some forms of corrosion attack.
[18]	IEC 60512-14-7:1997 Electromechanical components for electronic equipment - Basic testing procedures and measuring methods - Part 14: Sealing tests - Section 7: Test 14g: Impacting water	Defines a standard test method to assess the effects of impacting water or specified fluid on electrical connecting devices.
[19]	IEC 60529:1989 + AMD1:1999 + AMD2:2013 CSV Consolidated version Degrees of protection provided by enclosures (IP code)	Applies to the classification of degrees of protection provided by enclosures for electrical equipment with a rated voltage not exceeding 72.5 kV. Has the status of a basic safety publication in accordance with IEC Guide 104.

Ref.	Standards and reference documents	Description
[20]	IEC TR 61000-4-1:2016 Electromagnetic compatibility (EMC) - Part 4-1: Testing and measurement techniques - Overview of IEC 61000-4 series	Gives applicability assistance to the users and manufacturers of electrical and electronic equipment on EMC standards within the IEC 61000-4 series on testing and measurement techniques. Provides general recommendations concerning the choice of relevant tests.
[21]	IEC 61000-4-2:2008 Electromagnetic compatibility (EMC) - Part 4-2: Testing and measurement techniques - Electrostatic discharge immunity test	Relates to the immunity requirements and test methods for electrical and electronic equipment subjected to static electricity discharges, from operators directly, and to adjacent objects. Additionally defines ranges of test levels which relate to different environmental and installation conditions and establishes test procedures. The object of this standard is to establish a common and reproducible basis for evaluating the performance of electrical and electronic equipment when subjected to electrostatic discharges. In addition, it includes electrostatic discharges which may occur from personnel to objects near vital equipment.
[22]	IEC 61000-4-3:2020 Electromagnetic compatibility (EMC) - Part 4-3: Testing and measurement techniques - Radiated, radio-frequency, electromagnetic field immunity test	Applies to the immunity of electrical and electronic equipment to radiated electromagnetic energy. Establishes test levels and the required test procedures. Establishes a common reference for evaluating the performance of electrical and electronic equipment when subjected to radio-frequency electromagnetic fields.
[23]	IEC 61000-4-4:2012 Electromagnetic compatibility (EMC) - Part 4-4: Testing and measurement techniques - Electrical fast transient/burst immunity tests	Establishes a common and reproducible reference for evaluating the immunity of electrical and electronic equipment when subjected to electrical fast transient/burst on supply, signal, control and earth ports. The test method documented in this part of IEC 61000-4 describes a consistent method to assess the immunity of an equipment or system against a defined phenomenon.
[24]	IEC 61000-4-5:2014+AMD1:2017 CSV Consolidated version Electromagnetic compatibility (EMC) - Part 4-5: Testing and measurement techniques - Surge immunity test	Relates to the immunity requirements, test methods, and range of recommended test levels for equipment to unidirectional surges caused by overvoltages from switching and lightning transients. Several test levels are defined which relate to different environment and installation conditions. These requirements are developed for and are applicable to electrical and electronic equipment. Establishes a common reference for evaluating the performance of equipment when subjected to high-energy disturbances on the power and inter-connection lines.
[25]	IEC 61000-4-6 (2013) Electromagnetic compatibility (EMC) - Part 4-6: Testing and measurement techniques - Immunity to conducted disturbances, induced by radio-frequency fields	Relates to the conducted immunity requirements of electrical and electronic equipment to electromagnetic disturbances coming from intended radio-frequency (RF) transmitters in the frequency range 9 kHz – 80 MHz. Equipment not having at least one conducting cable (such as mains supply, signal line or earth connection), which can couple the equipment to the disturbing RF fields is excluded.

Ref.	Standards and reference documents	Description
[26]	IEC 61000-4-8:2009 (Ed. 2.0) Electromagnetic compatibility (EMC) - Part 4-8: Testing and measurement techniques-- Power frequency magnetic field immunity test	Relates to the immunity requirements of equipment, only under operational conditions, to magnetic disturbances at power frequency related to: – residential and commercial locations; – industrial installations and power plants; and – medium voltage and high voltage sub-stations.
[27]	IEC 61000-4-11:2020 Electromagnetic compatibility (EMC) - Part 4-11: Testing and measurement techniques - Voltage dips, short interruptions and voltage variation immunity tests for equipment with input current up to 16 A per phase	Defines the immunity test methods and range of preferred test levels for electrical and electronic equipment connected to low-voltage power supply networks for voltage dips, short interruptions, and voltage variations. This standard applies to electrical and electronic equipment having a rated input current not exceeding 16 A per phase, for connection to 50 Hz or 60 Hz AC networks.
[28]	IEC 61000-4-12:2017 Electromagnetic compatibility (EMC) - Part 4-12: Testing and measurement techniques - Ring wave immunity test	Relates to the immunity requirements and test methods for electrical and electronic equipment, under operational conditions, to non-repetitive damped oscillatory transients (ring waves) occurring in low-voltage power, control and signal lines supplied by public and non-public networks.
[29]	IEC 61000-6-1:2016 Electromagnetic compatibility (EMC) - Part 6-1: Generic standards - Immunity for residential, commercial and light-industrial environments	Defines the immunity test requirements in relation to continuous and transient, conducted and radiated disturbances, including electrostatic discharges, for electrical and electronic apparatus intended for use in residential, commercial and light-industrial environment, and for which no dedicated product or product-family standard exists. Immunity requirements in the frequency range 0 kHz - 400 GHz are covered and are specified for each port considered. This standard applies to apparatus intended to be directly connected to a low-voltage public mains network or connected to a dedicated DC source which is intended to interface between the apparatus and the low-voltage public mains network.

Ref.	Standards and reference documents	Description
[30]	IEC 61000-6-2:2016 Electromagnetic compatibility (EMC) - Part 6-2: Generic standards - Immunity for industrial environments	<p>Applies to electrical and electronic apparatus intended for use in industrial environments, for which no dedicated product or product-family immunity standard exists. Immunity requirements in the frequency range 0 Hz-400 GHz are covered, in relation to continuous and transient, conducted and radiated disturbances, including electrostatic discharges. Test requirements are specified for each port considered.</p> <p>Apparatus intended to be used in industrial locations are characterised by the existence of one or more of the following:</p> <ul style="list-style-type: none"> - a power network powered by a high or medium voltage power transformer dedicated to the supply of an installation feeding manufacturing or similar plant; - industrial, scientific and medical (ISM) apparatus; - heavy inductive or capacitive loads that are frequently switched; - currents and associated magnetic fields that are high.
[31]	IEC 62052-11:2020 Electricity metering equipment - General requirements, tests and test conditions - Part 11: Metering equipment	Covers type tests for electricity metering equipment for indoor and outdoor application and to newly manufactured equipment designed to measure the electric energy on 50 Hz or 60 Hz networks, with a voltage up to 600 V. It applies to electromechanical or static meters for indoor and outdoor application consisting of a measuring element and register(s) enclosed together in a meter case. It also applies to operation indicator(s) and test output(s).
[32]	IEC 62053-52:2005 Electricity metering equipment (AC) - Particular requirements - Part 52: Symbols	Applies to letter and graphical symbols intended for marking on and identifying the function of electromechanical or static AC electricity meters and their auxiliary devices. The symbols specified in this standard shall be marked on the name-plate, dial plate, external labels or accessories, or shown on the display of the meter as appropriate.
[33]	ISO 4892-3:2016 Plastics – Methods of exposure to laboratory light sources – Part 3: Fluorescent UV lamps	Specifies methods for exposing specimens to fluorescent UV radiation and water in apparatus to designed reproduce the weathering effects that occur when materials are exposed in actual end-use environments to daylight, or to daylight through window glass.

Annex B

Estimation of combined errors

(Informative)

This Guide permits a base maximum permissible error plus an error shift caused by influence quantities. The actual error of a complying EVSE when in use could therefore exceed the base maximum permissible error. There is a need to estimate an overall maximum permissible error that indicates the largest error that can reasonably be attributed to an EVSE type that complies with this Guide. This entails estimating the errors of a measurement of an arbitrary EVSE within the rated operating conditions.

However, adding the base maximum permissible error and all error shifts algebraically would give a much too pessimistic estimate of the metering uncertainty, for two reasons. For an arbitrary set of influence factor values, some of the error shifts will be low and some will probably have opposite signs, tending to cancel each other out. Furthermore, the EVSE is an integrating device, thus the errors caused by influence quantities will average out to some extent as the values of the influence factors vary over time.

If we make the following assumptions:

- a) the integrating effect may be ignored,
- b) none of the effects of the influence factors are correlated,
- c) the values of the influence quantities are more likely to be close to the reference values than to limits of the rated operated conditions,
- d) the influence quantities, and the effects of the influence factors, can be treated as Gaussian distributions, and thus a value of half the maximum permissible error shift can be used for the standard uncertainty,

then the combined maximum permissible error (assuming a coverage factor of two corresponding to a coverage probability of approximately 95 %) can be estimated using the formula⁽¹⁾:

$$v = 2 \times \sqrt{\frac{v_{\text{base}}^2}{4} + \frac{v_{\text{voltage}}^2}{4} + \frac{v_{\text{frequency}}^2}{4} + \frac{v_{\text{unbalance}}^2}{4} + \frac{v_{\text{harmonic}}^2}{4} + \frac{v_{\text{temperature}}^2}{4}}$$

where:

v_{base}	is the base maximum permissible error;
v_{voltage}	is the maximum error shift permitted for voltage variation;
$v_{\text{frequency}}$	is the maximum error shift permitted for frequency variation;
$v_{\text{unbalance}}$	is the maximum error shift permitted for unbalance variation;
$v_{\text{harmonics}}$	is the maximum error shift permitted for the variation of harmonic content;
$v_{\text{temperature}}$	is the maximum error shift permitted for temperature variation.

Note (1): This is in line with OIML G 1-100:2008 *Evaluation of measurement data – Guide to the expression of uncertainty in measurement (GUM)*.

Annex C

Estimation of combined error based on type test results and specific conditions

(Informative)

Method 1

The combined maximum error can also be estimated for a particular EVSE type using type test results. Type test results can often show a smaller variation than that required by this Guide, leading to an assured smaller value for the overall maximum error.

Keeping the assumption of a Gaussian distribution being valid, the combined maximum error can then be estimated from a combination of test results using the formula:

$$e_{c(p,i)} = \sqrt{(e^2(PF_p, I_i) + \delta e_{p,i}^2(T) + \delta e_{p,i}^2(U) + \delta e_{p,i}^2(f))}$$

where:

For each current I_i and each power factor PF_p

$e(PF_p, I_i)$ is the intrinsic error of the EVSE measured in the course of the tests, at current I_i and power factor PF_p ;

$\delta e_{p,i}(T)$, $\delta e_{p,i}(U)$, $\delta e_{p,i}(f)$ are the maximum additional errors measured in the course the test, when the temperature, the voltage and the frequency are respectively varied over the whole range specified in the rated operated conditions, at current I_i and power factor PF_p

Method 2

When assuming that a Gaussian distribution may no longer be valid, instead a rectangular distribution should be assumed for the effects of influence factors.

Thus, the combined maximum error can then be estimated from a combination of test results using the formula⁽¹⁾:

$$e_c = 2 \times \sqrt{\frac{e_{\text{base}}^2}{3} + \frac{e_{\text{voltage}}^2}{3} + \frac{e_{\text{frequency}}^2}{3} + \frac{e_{\text{unbalance}}^2}{3} + \frac{e_{\text{harmonic}}^2}{3} + \frac{e_{\text{temperature}}^2}{3}}$$

where:

e_{base} is the maximum error obtained in the test for base maximum error, taking into account the measurement uncertainty of the type test⁽²⁾;

e_{voltage} is the maximum error shift obtained in the test for voltage variation, taking into account the measurement uncertainty of the type test;

$e_{\text{frequency}}$	is the maximum error shift obtained in the test for frequency variation, taking into account the measurement uncertainty of the type test;
$e_{\text{unbalance}}$	is the maximum error shift obtained in the test for unbalance variation, taking into account the measurement uncertainty of the type test;
$e_{\text{harmonics}}$	is the maximum error shift obtained in the test for variation of harmonic content, taking into account the measurement uncertainty of the type test;
$e_{\text{temperature}}$	is the maximum error shift obtained in the test for temperature variation, taking into account the measurement uncertainty of the type test.

Note (1): Components contributing to the combined error may be selected by national or regional authorities and should at least comprise: e_{base} , $e_{\text{frequency}}$, $e_{\text{temperature}}$ and e_{voltage} .

Note (2): The measurement uncertainty must be included in each component, e_i , of the overall error. Since one term is a known value and the other an uncertainty they cannot be treated as two uncorrelated statistical distributions, and must hence be added algebraically.

The effects of correlations between factors such as load profiles and ambient temperature variation on EVSE accuracy have not been included in the above calculations, but could be modelled in situations where appropriate.